

EWPX 161(/E) rel. 7/97 ing

electronic controller for refrigerating units

WHAT IT IS

EWPX 161(/E) is a digital microprocessor based device designed to control refrigerating units; it is particularly suitable for applications on "static" units operating at low or normal temperature.

The instrument is provided with one relay output to control the compressor, and an input probe for temperature regulation.

HOW IT IS MADE

- **Housing:** plastic resin PC+ABS extinguishing grade V0
- **Size:** front panel 76x34 mm, depth 58 mm
- **Mount:** panel mount on 71x29 mm hole
- **Protection:** front IP65
- **Connections:** on screw terminal block for wires max 2.5 mm² (one wire only per block in compliance with VDE regulations)
- **Remote connection:** serial connection to the EWPX ECHO repeater (version /E only)
- **Serial connection:** TTL port for the connection to the EWRS 485 interface for TELEVIS system linking
- **Display:** on 3 digit display (digit height 12.5 mm)
- **Output:** 1 relay output 8(3)A 250V AC for compressor (in exchange)
- **Analogue input:** NTC probe for temperature regulation
- **Resolution:** 1 °C
- **Accuracy:** better than 0,5% end of scale
- **Consumption:** 3 VA (5 VA in the "/E" version when the EWPX ECHO module is connected)
- **Power supply:** 12 Vac/dc ±15%

GENERAL DESCRIPTION

EWPX 161(/E) is a digital microprocessor based device designed to control refrigerating units; it is particularly suitable for applications on "static" units operating at low or normal temperature.

The instrument is provided with one relay output to control the compressor, and an input probe for temperature regulation. EWPX 161(/E) can be connected to the TELEVIS system (through the special interface module EWRS 485) and (version /E only) to the EWPX ECHO repeater; such repeater allows remote displaying of the temperature reported on the instrument display.

A range of alphanumeric parameters allows the configuration of EWPX 161(/E) according to its application.

EWPX 161(/E) is available in the new two key front panel 32x74 (ELIWELL standard).

OPERATION

When operating in the field of refrigeration the temperature control is performed with a positive differential; the compressor stops when the Setpoint temperature is reached and restarts when the temperature reaches Setpoint plus the differential. The on-board microprocessor provides several timing functions for the defrost; the defrost cycle as well the defrost cycle duration are user selectable.

A series of "safety controls" (delay at start-up, minimum disable time, minimum time between activations) protects the compressors from close starts.

In case of probe error or temperature alarm the instrument signals the event through the Televis system.

The minimum and maximum temperature alarms can be excluded for a certain time from start-up and/or after a defrost.

These functions can be easily customised by setting some programming parameters. Other parameters allow to suite the instrument to various applications.

COMMANDS ON FRONT PANEL

The instrument is provided with two keys: "UP" and "SET/DOWN".

SET/DOWN: by pressing and releasing it the Setpoint is displayed, the "SET" led is turned on.

To change the Setpoint value use the "UP" and "SET/DOWN" keys within 5 seconds. If no operation is performed for more than 5 seconds normal mode is restored and the new value is automatically acquired.

The same button is used to increase values during Setpoint change or parameters programming. When held pressed a fast increase is performed.

UP: button used to increase values. It is used to change both the Setpoint and the parameters. When held pressed a fast increase is performed. When held pressed for more than 7 seconds, this key also allows manual activation of the defrost cycle (the function is not enabled during Setpoint or parameter programming).

The "DEFROST" led blinks during manual defrost.

Led "COMPRESSOR": led related to the compressor relay. On when the compressor is operating.

Led "SET": on during Setpoint setting and displaying, blinking during parameters programming.

Led "DEFROST": led related to defrost. On when defrost is in progress, blinking in case of manual defrost.

DISPLAYING AND SETTING THE SETPOINT

To display the Setpoint value press and release key "SET/DOWN"; the Setpoint is displayed and the "SET" led turns on. To change the Setpoint use the "UP" and "SET/DOWN" keys within 5 seconds. If no operation is performed for more than 5 seconds normal mode is restored.

MANUAL ACTIVATION OF THE DEFROST CYCLE

The manual activation of the defrost cycle is performed by holding the "UP" key pressed for more than 7 seconds (the key is not enabled during Setpoint or parameters programming). Such activation is disabled during dripping.

Led "DEFROST" blinks during the manual defrost cycle.

DISPLAYING PROBE VALUES

The instrument provides one input port for probe to regulate the temperature control. By pressing and releasing keys "UP" and "SET/DOWN" simultaneously, the label "CPr" (Compressor Probe) is displayed; by pressing and releasing the "SET/DOWN" key the display shows the value of the regulation probe.

KEYBOARD LOCKING

Through a special programming of the "Loc" parameter, the keyboard can be disabled to prevent undesired operation or changes in the instrument settings.

When the keyboard is locked only display (no changes) is allowed both for Setpoint and all but the "Loc" parameter to allow keyboard unlock. When the keyboard is locked no manual activation of the defrost cycle is permitted.

PASSWORD TO ACCESS PARAMETERS PROGRAMMING

The instrument allows to set an access password to enter parameters programming mode.

To set (or change) the password enter parameter "PAS" and input a value from 1 to 15 (when 0 is input the password is disabled). The password is activated when the parameters programming phase is quitted.

In case a password is enabled, when access to the programming phase is requested, the "PAS" label is displayed. Press the "SET/DOWN" key to enter password setting, use the "UP" and "SET/DOWN" keys to change the password. If the password is correct by pressing "SET/DOWN" and then "UP" programming mode shall be entered, otherwise it shall be automatically quitted.

PARAMETERS PROGRAMMING

Parameters programming mode can be accessed by holding keys "UP" and "SET/DOWN" pressed for more than 7 seconds.

The first label is displayed and the "SET" led keeps blinking as long as parameters programming mode is enabled. To access other parameters press "UP" or "SET/DOWN". To display the value of the parameter indicated by the label press "UP" and "SET/DOWN" simultaneously. To change its value press "UP" or "SET/DOWN". The new values are automatically stored when programming mode is exited (after no key is pressed for some seconds).

PARAMETERS DESCRIPTION

diF: diFferential.

Setpoint intervention differential. For applications in the field of refrigeration the differential shall be set to positive values: the compressor stops when the Setpoint is reached (according to data detected by the regulation probe) and restarts when the temperature reaches Setpoint plus the differential.

LSE: Lower SET.

Minimum value allowed for Setpoint. Usually set to the minimum value that can be measured by the probe.

HSE: Higher SET.

Maximum value allowed for Setpoint.

dit: defrost interval time.

Defrost interval time in hours.

dct: defrost counting type.

Counting mode for the defrost interval.

dF = digifrost Feature (DIGIFROST® method; only the operation time of the compressor is counted);

DEFAULT SETTINGS - STANDARD MODELS

Parameter	Description	Range	Default	Unit
diF	diFferential	-12...12	2	°C / °F
LSE	Lower SET	-999...HSE	-50	°C / °F
HSE	Higher SET	LSE...999	40	°C / °F
dit	defrost interval time	0...31	6	hours
dct	defrost counting type	dF / rt / SC / Fr	dF	flag
doh	defrost offset hour	0...59	0	minutes
dEt	defrost Endurance time	1...250	30	minutes
dPo	defrost (at) Power-on	n / y	n	flag
ddL	defrost display Lock	n / y / Lb / Lg	n	flag
Att	Alarm temperature type	Ab / re	re	flag
HAL	High ALarm	-999...999	50	°C / °F
LAL	Low ALarm	-999...999	-50	°C / °F
AFd	Alarm (Fan) differential	1...50	2	°C / °F
PAO	Power-on Alarm Override	0...10	2	hours
dAo	defrost Alarm override	0...999	60	minutes
tAo	temperat. Alarm override	0...250	0	minutes
cPP	compressor Probe Prot.	oF / on / dc	on	flag
Ont	On time (compressor)	0...250	10	minutes
OFt	OFF time (compressor)	0...250	10	minutes
ctP	compr. type Protection	nP/don/doF/dbi	doF	flag
cdP	compr. delay Protection	0...15	0	minutes
odo	output delay (at) on	0...99	0	minutes
CAL	CALibration	-12...12	0	°C / °F
dEA	dEvice Address	0...14	0	number
FAA	FAMily Address	0...14	0	number
Loc	(keyboard) Lock	n / y	n	flag
PAS	PASsword	0...15	0	number
rEL	rElease firmware	/	/	/
tAb	tAble of parameters	/	/	/

rt = real time (the instrument operation time is counted);

SC = Stop Compressor (defrost is performed whenever the compressor stops);
Fr = Free (the compressor relay is freed from defrost functions, thus continuing to regulate according to the Setpoint).

doh: defrost offset hour.

Delay time for defrost start; in minutes.

dEt: defrost Endurance time.

Defrost time-out; in minutes.

dPo: defrost (at) Power-on.

Defrost at power on.

y = yes; n = no.

ddL: defrost display Lock.

Display lock during defrost.

n = no; during defrost the display shows the value read by the room probe.

y = yes; during defrost the display shows the last value read before defrost by the room probe.

Lb = Label ("defrost"); during defrost the display shows label "dEF" (dEFrost), indicating defrost is in progress.

Lg = Label ("dégivrage"); during defrost the display shows the label "dEg" ("dEgivrage"), indicating defrost in progress.

NOTA: in case "y", "Lb" or "Lg" are selected the display will be locked until the Setpoint temperature is reached in the room probe.

Att: Alarm temperature type.

Interpretation mode for parameters "HAL" and "LAL".

Ab = absolute;

re = relative (referred to Set).

HAL: High ALarm.

Maximum temperature alarm. When this value is exceeded the Televis alarm signal is triggered.

LAL: Low ALarm.

Minimum temperature alarm. When the temperature is below this value the Televis alarm signal is triggered.

AFd: Alarm (Fan) differential.

Operating differential for temperature alarms.

PAO: Power-on Alarm Override.

Alarm exclusion after instrument power on; in hours.

dAo: defrost Alarm override.

Temperature alarm exclusion after defrost; in minutes.

tAo: temperature Alarm override.

Temperature alarm signal delay; in min-

utes.

cPP: compressor Probe Protection.

Allows the selection of the compressor state in case of faulty probe.

oF = relay OFF for faulty probe.

on = relay ON for faulty probe.

dc = duty cycle; the ON and OFF times of the relay are set by parameters "Ont" and "OFt".

Ont: On time (compressor).

ON time for the compressor (when CPP = dc); in minutes.

OFt: OFF time (compressor).

OFF time for the compressor (when CPP = dc); in minutes.

ctP: compressor type Protection.

Allows to select the protection type against close starts of the compressor the time is set through the following parameter).

nP = no Protection.

don = delay on start. Delay in the activation of the relay.

doF = delay at switching oFf. Minimum time for delay switching off.

dbi = delay between two successive starts. Minimum time between two subsequent relay starts.

cdP: compressor delay Protection.

Time referred to the previous parameter; in minutes.

odo: output delay (at) on.

Output activation delay after instrument power on; in minutes.

CAL: CALibration.

Allows calibration of the displayed value (measured by the display probe) in case it is different from a known value. Usually set to "0".

dEA: dEvice Address.

Allows to select the device address within a remote control network.

FAA: Family Address.

Allows to select the device family within a remote control network.

Loc: keyboard Lock.

Allows to disable keyboard operation to prevent undesired operation or changes in the instrument settings.

When the keyboard is locked only display (no changes) is allowed both for Setpoint and all parameters but the "Loc" parameter to allow keyboard unlock.

y = yes; n = no.

PAS: PASsword.

Allows to select the password value (refer to section "Password to access parameters programming").

0 = no password is required to enter parameters programming.

1...15 = values allowed for the password.

rEL: FirmwAre rELease.

Read only parameter showing the release code of the device.

tAb: tAbLe of parameters.

Configuration index for factory set parameters; cannot be changed by the user.

MECHANICAL MOUNT

The instrument is designed for panel mount. Drill a 29x71 mm hole and intro-

CONNECTIONS

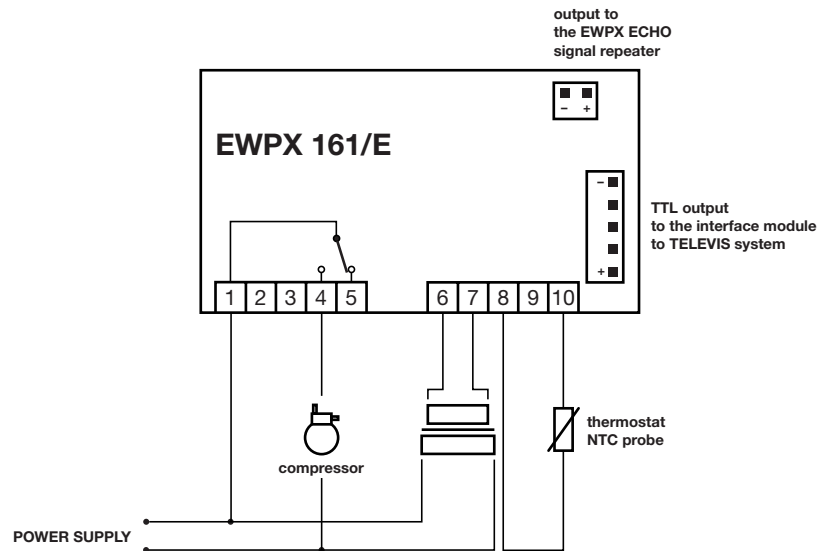

duce the instrument, then fix it with the special bracket (included).

The operating temperature range for correct operation is from -5 to 65 °C. Do not install the instrument in moist and/or dirty places; it is suitable for operation in environments with an ordinary pollution level. Leave enough room for air circulation by the cooling holes of the instrument.

ELECTRICAL CONNECTIONS

EWPX 161(/E) is provided with one relay output, one serial output for the connection to the TELEVIS system and another serial output for the EWPX ECHO repeater (version /E only).

The instrument includes a screw terminal block for the connection of electrical cables with a maximum 2.5 mm² section (one wire only for each block, according to VDE regulations).

Relay outputs are free from voltage.

EWPX 161(/E) is provided with one output (exchange contact) for compressor relay. Do not exceed the maximum contact capacity: 8(3)A 250V AC; in case of heavier loads use a suitable contactor.

Check the power voltage complies with the instrument requirements: 12 Vca/cc $\pm 15\%$ (very low safety voltage).

The NTC probe has no insertion polarity and can be lengthened using a common bipolar cable (bearing in mind that a very long probe implies worse instrument performances referred to the EMC).

Outputs for the connection of the EWPX ECHO repeater (version /E only) and the EWRS 485 interface module of the TELEVIS system require connections according to the indicated polarity.

The probe cable, the connection cable for the EWPX ECHO repeater (version /E only), the connection cable for the EWRS 485 interface module shall be kept far from the relay cables both for EMC and safety reasons. The coordinated European safety

regulations state that the relay contacts (and generally speaking, all parts subject to dangerous voltage) shall be kept away from the very low safety voltage connections (probe, Televis serial, power supply) using insulation systems and distances providing at least a double or reinforced insulation.

However EMC requirements for correct operation suggest/impose better accuracy in such separation by using separated insulating pipes and special cable fixing systems.

EWPX ECHO (version /E only) operates at very low safety voltage and shall be installed respecting the same insulation/separation conditions from the parts bearing voltage and the wires of the relay contacts.

ERROR MESSAGES

EWPX 161(/E) displays error message "E1" in case of shorted, interrupted or disconnected probe. The message is also displayed in case of "under range", i.e. when the lower display limit (-55 °C) is exceeded, or in case of "over range", i.e. when the upper display limit (125 °C) is exceeded.

In case of error the Televis system alarm is immediately activated.

Before replacing the probe check its connections.

TECHNICAL DATA

Housing: plastic resin PC+ABS extinguishing grade V0.

Size: front panel 76x34 mm, depth 58 mm.

Mount: panel mount on 71x29 mm hole.

Protection: front IP65.

Connections: on screw terminal block for wires max 2.5 mm² (one wire only per block in compliance with VDE regulations).

Remote connection: serial connection to the EWPX ECHO repeater (version /E only).

Serial connection: TTL port for the connection to the EWRS 485 interface for

TELEVIS system linking.

Display: on 3 digit display (digit height 12,5 mm).

Commands: all located on front panel.

Data storage: on non-volatile memory (EEPROM).

Operating temperature: -5...65 °C; (23...149 °F).

Storage temperature: -30...75 °C; (-22...167 °F).

Output: 1 relay output 8(3)A 250V AC for compressor (in exchange).

Analogue input: NTC probe for temperature regulation.

Range: -50...100 °C (-58...212 °F).

Resolution: 1 °C.

Accuracy: better than 0,5% end of scale.

Consumption: 3 VA (5 VA in the "/E" version when the EWPX ECHO module is connected).

Power supply: 12 Vac/dc ±15%.

Eliwell S.p.A.

via dell'Artigianato, 65
Zona Industriale
32010 Pieve d'Alpago (BL)
Italy

Telephone +39 (0)437 986111

Facsimile +39 (0)437 989066

A Siebe Group Company