

# EWPX 185(/E) rel. 11/97 ing

## electronic controller for refrigerating units

### WHAT IT IS

**EWPX 185(/E) is a digital instrument suitable for any application in the control of refrigerating units; it is provided with four relay outputs, one of which is devoted to the compressor, one to the defrost system and two can be configured for other users.**

### HOW IT IS MADE

- **Housing:** PC-ABS plastic resin, extinguishing grade V0
- **Size:** front panel 76x34 mm, depth 58 mm
- **Mount:** on panel hole size 71x29 mm
- **Protection:** front IP65
- **Connections:** on screw terminal blocks for wires max 2.5 mm<sup>2</sup> (one wire per terminal according to VDE regulations) for other connections
- **Remote connection:** double serial port for the connection to the EWPX ECHO 1 e 2 repeater (version /E only)
- **Serial connection:** TTL port for the connection to the Televis system
- **Real time clock autonomy:** 5 hours approx.
- **Outputs:** 2 outputs on N.O. relay for compressor and defrost system; 2 programmable outputs on exchange relay OUT 1 and OUT 2
- **Inputs:** three NTC probes for compressor, defrost and auxiliary; one programmable digital input
- **Resolution:** 1 °C
- **Accuracy:** better than 0.5% end of scale
- **Power supply:** 12 Vac/dc

### GENERAL DESCRIPTION

EWPX 185(/E) is a digital instrument suitable for any application in the control of refrigerating units; it is provided with four relay outputs, one of which is devoted to the compressor, one to the defrost system and two (OUT1 and OUT2) can be configured for other users such as:

OUT1

- fans;
- defrost;
- auxiliary;
- compressor;
- on/off;
- alarm;
- light.

OUT2

- light;
- alarm;
- fans.

The instrument provides as inputs two probes for temperature regulation and defrost management and a third auxiliary probe to be used according to requirements; it also provides a digital configurable input (external alarm, keyboard lock, continuous cycle, light, micro-gate, pre-heating, pressure switch, reduced set, on/off and auxiliary).

EWPX 185(/E) provides, as standard features, optional connection to the TELEVIS system (through the special EWRS 485 interface module) and double connection capabilities (version /E only) to the EWPX ECHO repeater, which allows to display the temperature measured by the instrument in two remote displays.

The instrument also provides an internal clock for defrost management and a led for alarm signal. An internal backup device ensures time count even in case of power failure.

EWPX 185(/E) is available in the two-key

32x74 standard ELIWELL format complying with VDE and UL regulations.

### OPERATION

The temperature regulation always occurs with the differential set to positive values; the compressor stops when the set Setpoint is reached and restarts when the temperature reaches Setpoint plus the differential.

The instrument allows to select two different defrost types: electrical (the compressor is stopped) or cycle inversion (warm gas; the compressor keeps on operating). It is also possible to select the interval between defrosts and the count type for the interval (alternatively, the clock option allows to set up to six different times for defrost start), their stop temperature and a maximum time (time-out) after which defrost is interrupted in any case.

The probe controlling the defrost cycle is also used to control the evaporator's fans; the user can set the stop temperature, the delay time after defrost and the relation of fans with the compressor and the door switch contact.

A series of safety systems (delay at start-up, minimum stop time, minimum time between two stops) protects the compressor from close starts.

In case of probe error or temperature alarm the instrument signals the event through the alarm led on the front panel.

The minimum and maximum temperature alarms can be excluded for a certain time from startup and/or after a defrost.

### COMMANDS

The instrument is provided with two keys: "UP" and "SET" (which also operates as "DOWN").

**SET:** by pressing and releasing it the



Setpoint will be displayed, the "SET" led turns on. To change it press "UP" or "DOWN"; if no key is pressed for some seconds "SET" programming mode is exited and the new value is stored.

**UP:** key used to increase values. Used to change both the Setpoint and the parameters. By holding it pressed a fast increase is performed.

The key also allows to manually activate the defrost cycle, by holding it pressed for more than 7 seconds (the function is not active in Setpoint or parameters programming mode), and to display the real time (by pressing and releasing it immediately). The "DEFROST" led blinks during defrost.

**DOWN:** key used to decrease values both in the Setpoint and the parameters programming modes. By holding it pressed a fast decrease is performed.

**"COMPRESSOR" Led:** Led related to the compressor relay. On when the compressor works.

**"SET" Led:** on during Setpoint setting and display, blinking during parameters programming.

**"DEFROST" Led:** Led related to the defrost relay. On when defrost is in progress, blinking in case of manual defrost.

**"ALARM" Led:** On in case of probe alarm or low/high temperature alarm.

**Led "out 1":** led related to output 1.

**Led "out 2":** led related to output 2.

## DISPLAYING AND SETTING THE SETPOINT

To display the Setpoint value press and release "SET/DOWN"; the Setpoint value is displayed and the "SET" led is turned on. To change the Setpoint value operate on keys "UP" and "SET/DOWN" within 5 seconds; after such time normal mode will be restored.

## MANUAL ACTIVATION OF THE DEFROST CYCLE

The manual activation of the defrost cycle starts by holding the "UP" key pressed for more than 7 seconds (the key is not active during Setpoint or parameter programming). In case the defrost conditions are not suitable (e.g. the temperature of the evaporator probe exceeds the end defrost temperature) the display will show the blinking "dFu" (deFrost unable) label. During manual defrost the "DEFROST" led blinks.

## DISPLAYING PROBE VALUES

The instrument provides three probe inputs: temperature control, defrost management and temperature display.

The pressure and release of the "UP" and "SET/DOWN" keys simultaneously causes the label "CPr" (Compressor Probe) to be displayed; by pressing and releasing the "SET/DOWN" key the display shows the value on the control probe.

By pressing the "UP" key the display shows the label "EPt" (Evaporator Probe);

by pressing and releasing the "SET/DOWN" key the display shows the value of the defrost probe.

## KEYBOARD LOCKING

A special programming of the "Loc" parameter allows to disable the keyboard in order to avoid unauthorised operations or parameter changes.

When the keyboard is disabled the Setpoint and the parameters can only be displayed (not changed), except parameter "Loc" to allow keyboard release.

## PASSWORD TO ACCESS PARAMETER PROGRAMMING

A password can be set to allow access to the parameter programming phase. To set (or change) the password access parameter "PAS" and type a number from 1 to 15 (0 to disable the password). The password will be enabled when exiting from the parameter programming phase.

In case the password is enabled, when requesting access to the parameter programming phase the label "PAS" is displayed. Press the "SET/DOWN" key to access password programming and change it using keys "UP" and "SET/DOWN". If the password is correct the pressure of keys "SET/DOWN" and then "UP" enables access to the programming phase, otherwise it will automatically quit.

## PARAMETERS PROGRAMMING

The programming phase can be accessed pressing the "UP" and "SET/DOWN" keys simultaneously for more than 7 seconds. The first label is displayed and the "SET" led starts blinking. To access other parameters press "UP" or "SET/DOWN"; to display the value of the parameter shown on the display press "UP" and "SET/DOWN" simultaneously. To change its value press "UP" or "SET/DOWN".

The storage of new values takes place automatically when exiting the programming mode (no key pressed for some seconds).

## REAL TIME PROGRAMMING

EWPX 185(E) is provided with an internal clock for defrost control. To display the set real time press and release the "UP" key (clock); the display will alternatively show the hours (preceded by letter "h") and the minutes (followed by " ' ").

To change the set time press and release the "UP" key (clock) then hold the "SET" key pressed for about 7 seconds: as the device displays the hours or minutes (press keys simultaneously to skip from one display mode to the other) use the "UP" or "DOWN" keys to set the required value.

The new values are automatically stored when exiting programming mode (after no key is pressed for 10 seconds).

EWPX 185(E) is provided with an internal backup system which ensures the count

proceeds even in case of power failure. The autonomy is 5 hours approximately, after such time the instrument does not retain the real time, which shall be set again (at startup count restarts from value "h00-00'").

The loss of the memory data after a power failure is indicated at startup by label "dte" on the display. This only happens when the clock option is enabled (see parameter "dit") by the display of label "dte" (defrost time error) and of the room value, alternatively.

## PARAMETERS DESCRIPTION

**diF:** differential.

Setpoint intervention differential.

For applications in the field of refrigeration the differential shall be set to positive values; the compressor will stop when the Setpoint is reached (according to the control probe) and start again when the temperature reaches the Setpoint plus the differential.

**rSo:** reduced Set out.

**LSE:** Lower SET.

Minimum value that can be assigned to Setpoint.

Usually set to the minimum value measurable by the probe.

**HSE:** Higher SET.

Maximum value that can be assigned to Setpoint.

**dtY:** defrost type.

EL = electric defrost;

in = cycle inversion defrost (hot gas).

**dit:** defrost interval type.

Defrost interval in hours or minutes.

**dct:** defrost counting type.

Counting mode for the defrost interval.

dF = digifrost Feature (DIGIFROST® method; only the operation time of the compressor is counted).

rt = real time (the count is based on the operating time of the instrument).

SC = Stop Compressor (the defrost takes place whenever the compressor stops).

Fr = Free (the compressor relay has no relation with the defrost functions and continues to regulate on Setpoint).

**dt1...dt6:** defrost time 1...6.

Parameters to set the time (real) for defrost starts (accessible only when "dit" is set to 0).

0...23 = real hours; oF = oFF (disabled).

Note: it is not necessary to input parameters' values (dt1...dt6) in the exact time sequence.

**doh:** defrost offset hour.

Defrost start delay time; in minutes.

**dEt:** defrost Endurance time.

Defrost time-out; in minutes or seconds.

**dSt:** defrost Stop temperature.

**POS:** POStpone defrost.

This provides for a postponement of a scheduled defrost cycle until such a moment that the condition which prevented the defrost to start (i.e. evaporator temperature higher than the defrost termination

## DEFAULT SETTINGS - STANDARD MODELS

Parameter	Description	Range	Default	Unit
<b>THERMOSTAT</b>				
diF	diFferential	-12...12	2	°C/°F
rSo	reduced Set out	-12...12	1	°C/°F
CAL	CALibration	-12...12	0	°C/°F
LSE	Lower SEt	-99...HSE	-50	°C/°F
HSE	Higher SEt	LSE...125	40	°C/°F
cPP	comp. Probe Protection	oF / on / dc	on	flag
Ont	On time (compressor)	0...250	10	minutes
OFt	OFF time (compressor)	0...250	10	minutes
ctP	compr. type Protection	nP/don/doF/dbi	doF	flag
cdP	compr. delay Protection	0...15	0	minutes
cct	continous cycle time	0...10	0	hours
<b>DEFROST</b>				
dtY	defrost type	EL / in	EL	flag
dit	defrost interval time	0...31	6	hours
dct	defrost counting type	dF / rt / SC / Fr	dF	flag
dt1...dt6	defrost time 1...6	0...23...oF	oF	hours
doh	defrost offset hour	0...59	0	minutes
dEt	defrost Endurance time	1...250	30	minutes
dSt	defrost Stop temperature	-99...125	8	°C/°F
POS	POstpone defrost	n / y	n	flag
dPo	defrost (at) Power-on	n / y	n	flag
ddL	defrost display Lock	n / y / Lb / Lg	n	flag
<b>FANS</b>				
FSt	Fan Stop temperature	-99...125	2	°C/°F
Fdt	Fan delay time	0...250	0	minutes
dt	drainage time	0...250	0	minutes
dFd	defrost Fan disable	n / y	y	flag
AFd	Alarm (Fan) differential	1...50	2	°C/°F
Fco	Fan compressor on	oF / on	on	flag
Fod	Fan off (with opened) door	oF / on	oF	flag
<b>ALARMS</b>				
HAL	Higher ALarm	-99...120	50	°C/°F
LAL	Lower ALarm	-99...120	-50	°C/°F
PAO	Power-on Alarm Override	0...10	2	hours
dAo	defrost Alarm override	0...999	60	minutes
oAo	output (door) Alarm override	0...10	10	hours
cAo	continuos Alarm override	0...10	10	hours
tAo	temperature Alarm override	0...250	0	minutes
PEn	Pressurestat Error numbers	0...15	15	number
PEI	Pressurestat Error Interval	1...99	99	minutes
AOP	Alarm Output Polarity	di / in	in	flag
<b>LIGHT</b>				
dSd	door Switch disable	n / y	n	flag
dLt	delay Light	0...31	0	minutes
<b>CONFIGURABLE INPUTS/OUTPUTS</b>				
IS1	Input Selection 1	0...15	12	number
OS1	Output Selection 1	0...15	0	number
OS2	Output Selection 2	0...15	1	number
<b>TELE-ASSISTANCE</b>				
dEA	dEvice Address	0...14	0	number
FAA	FAMily Address	0...14	0	number

temperature) has corrected itself.

n = the prevailing defrost cycle is cancelled;

y = the defrost cycle is not cancelled, however is postponed.

**FSt**: Fan Stop temperature.

Fan stop temperature; a value read by the defrost probe exceeding the set value causes fans to stop.

**Fdt**: Fan delay time.

Delay time for fans activation after a defrost; in minutes.

**dt**: drainage time.

Dripping time in minutes.

**dPo**: defrost (at) Power-on.

y = yes; n = no

**ddl**: defrost display lock.

n = no; during defrost the display will show the temperature measured by the room probe.

y = yes; during defrost the display will show the last value measured by the room probe before defrost.

Lb = Label ("defrost"); during defrost the display will show the "dEF" (dEFrost) label to indicate defrost is in progress.

Lg = Label ("degivrage"); during defrost the display will show the "dEG" (dEGivrage") label to indicate defrost is in progress.

NOTE: in case "n" or "lb" is selected the display will be locked until the Setpoint on the room probe is reached.

**dFd**: defrost Fan disable.

Allows to select or deselect the exclusion of evaporator fans during defrost.

n = no; y = yes.

**HAL**: Higher ALarm.

Maximum temperature alarm.

**LAL**: Lower ALarm.

Minimum temperature alarm.

**AFd**: Alarm (Fan) differential.

Operating differential for temperature alarms.

**PAO**: Power-on Alarm Override.

Alarm exclusion after instrument start-up; in hours.

**dAo**: defrost Alarm override.

Alarm exclusion after defrost; in minutes.

**oAo**: output (door) Alarm override.

Exclusion time for temperature alarms after the door is opened; in hours.

**cAo**: continuous (cycle) Alarm override.

Alarm override time after a continuous cycle, in hours.

**tAo**: temperature Alarm override.

Delay for temperature alarm signalling; in minutes.

**cct**: continuous cycle time.

Duration of the continuous cycle, in hours; compressor runs continuously, regardless of thermostat.

**Fco**: Fan compressor on.

Allows to select or deselect fan stop when the compressor is OFF.

oF = yes; on = no.

**Fod**: Fan off (with opened) door.

Allows to select or deselect the fan block when the door is opened.

oF = yes; on = no.

**cPP**: compressor Probe Protection.

Allows the selection of the output state in

## DEFAULT SETTINGS - STANDARD MODELS

Parameter	Description	Range	Default	Unit
<b>VARIOUS</b>				
odo	output delay (at) on	0...99	0	minutes
dod	disable (with) opened door	n / y	n	flag
PrP	Probe Presence	nP / EP / AP / EAP	EAP	flag
CLO	CLOck frequency	/	/	Hertz
Loc	(keyboard) Lock	n / y	n	flag
PAS	PASsword	0...15	0	number
rEL	rELease firmware	/	/	/
Hdc	Hardware code	/	/	/
tAb	tABle of parameters	/	/	/

case of faulty probe.

oF = relay OFF in case of faulty probe.

on = relay ON in case of faulty probe.

dc = duty cycle; the ON and OFF times for the relay are defined by parameters "Ont" and "OFt".

**Ont**: On time (compressor).

ON time for the compressor (when CPP = dc); in minutes.

**OFt**: OFF time (compressor).

OFF time for the compressor (when CPP = dc); in minutes.

**ctP**: compressor type Protection.

Allows the selection of the protection type to prevent close startups of the output (time is set through the following parameter).

nP = no Protection.

don = delay on start. Delay on relay activation.

doF = delay at switching oFf. Minimum time for relay cut off.

dbl = delay between two successive starts.

**cdP**: compressor delay Protection.

Time referred to the previous parameter; in minutes.

**PEn**: Pressure Error number.

Number of pressure switch errors allowed within a period defined with parameter "PEI" without triggering the alarm.

**PEI**: Pressure Error Interval.

Time period during which a number of pressure switch errors are allowed as defined by parameter "PEn", without triggering the alarm.

**odo**: output delay (at) on.

Output activation delay after instrument power on; in minutes.

**dod**: disable (with) opened door.

Allows to select or deselect the option to turn users (compressor and evaporator fans) off when the door is open.

n = no; y = yes.

**dSd**: door Switch disable.

The light will automatically come on when the door is opened.

n = no; y = yes.

**PrP**: Presence Probe.

Allows to select the presence of the Evaporator probe.

nP = evaporator probe not present;

EP = evaporator probe present;

AP = not usable;

EAP = evaporator probe and temperature display probe presents.

**CAL**: CALibration.

It allows the calibration of the displayed value (measured by the display probe) in case it is different from a known sample value. Usually set to "0".

**IS1**: Input Selection 1.

**dEA**: dEvice Address.

Allows the selection of the device address in the remote control network.

**FAA**: FAMily Address.

Allows the selection of the device family in the remote control network.

**AOP**: Alarm Output Polarity.

di = direct; in = inverted.

**CLO**: CLOck frequency.

Reading double the mains frequency.

**OS1**: Output Selection (relay) 1.

**Loc**: keyboard Lock.

Allows to disable the keyboard to prevent unauthorised operations. When the keyboard is disabled only display (not modification) of Setpoint and parameters is allowed. Only the "Loc" parameter can be modified to permit keyboard unlock.

y = yes ; n = no.

**PAS**: PASsword.

Allows to set a password (see paragraph "Password to access parameter programming").

0 = no password required to access parameter programming;

1...15 = available values for the password.

**rEL**: rELease firmware.

Read-only parameter showing the release code of the product.

**OS2**: Output Selection (relay) 2.

**dLt**: delay Light.

**Hdc**: Hardware code.

Configuration index for factory set parameters; cannot be changed by the user.

**tAb**: tABle of parameters.

Summary of factory set parameters; cannot be modified by the user.

## MECHANICAL MOUNT

The instrument is designed for panel mount. Drill a 29x71 mm hole and introduce the instrument, then fix it with the special bracket (included).

The operating temperature range for correct operation is from -5 to 65 °C. Do not install the instrument in moist and/or dirty places; it is suitable for operation in environments with an ordinary pollution level. Leave enough room for air circulation by the cooling holes of the instrument.

## ELECTRICAL CONNECTIONS

EWPX 185(E) is provided with three relay outputs, one serial output for the connection to the TELEVIS system and another serial output for two EWPX ECHO repeater (version /E only).

The instrument includes a screw terminal block for the connection of electrical cables with a maximum 2.5 mm<sup>2</sup> section (one wire only for each block, according to VDE regulations).

Relay outputs, connected through two common terminal blocks, are free from voltage. Do not exceed the maximum allowed current 8(3)A 250V AC; in case of heavier loads use a suitable power contactor.

## TABELLA DI CONFIGURAZIONE DEI RELÈ

Relay	Output	Parameter	Regulator	Key	D.I.
Fans	OUT 1	OS1 = 0	fans	nothing	nothing
	OUT 2	OS2 = 3			
Auxiliary	OUT 1	OS1 = 1	nothing	nothing	IS1 = 3
Defrost	OUT 1	OS1 = 2	defrost	up/defrost	IS1 = 9
				premuto 7 sec.	
Compressor	OUT 1	OS1 = 4	compressor	nothing	IS1 = 14
On/Off	OUT 1	OS1 = 5	on/off	nothing	IS1 = 15
Alarm	OUT 1	OS1 = 6	alarm	nothing	IS1 = 11
	OUT 2	OS2 = 2			
Light	OUT 1	OS1 = 7	light	set/down	IS1 = 6 o 12
	OUT 2	OS2 = 1		premuto 7 sec.	

## CONNECTIONS

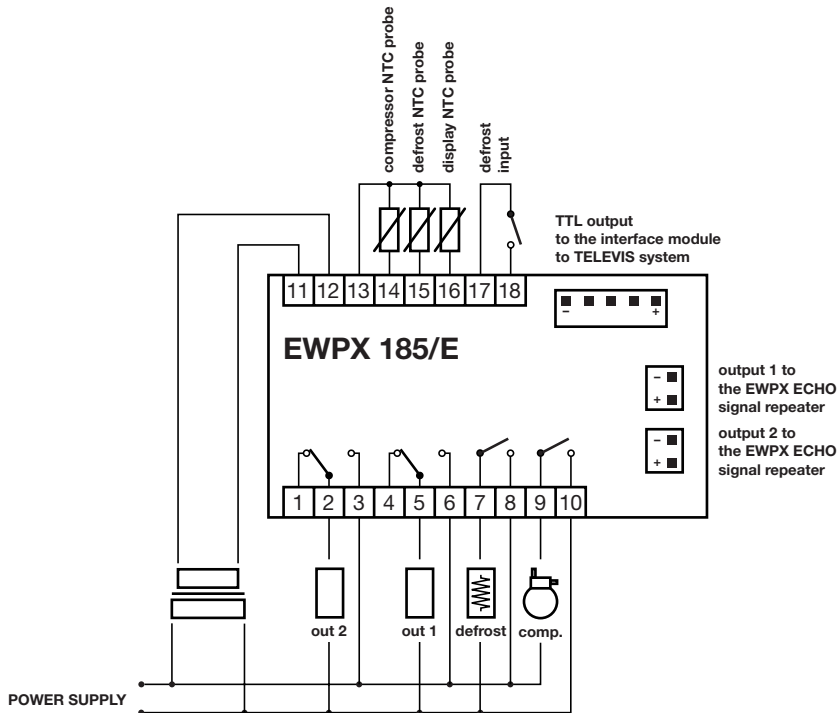

Check the power voltage complies with the instrument requirements: 12 Vca/cc  $\pm 15\%$  (very low safety voltage).

The NTC probe has no insertion polarity and can be lengthened using a common bipolar cable (bearing in mind that a very long probe implies worse instrument performances referred to the EMC).

Outputs for the connection of the EWPX ECHO repeater (version /E only) and the EWRS 485 interface module of the TELEVIS system require connections according to the indicated polarity.

The probe cable, the connection cable for the EWPX ECHO repeater (version /E only), the connection cable for the EWRS 485 interface module shall be kept far from the relay cables both for EMC and safety reasons. The coordinated European safety regulations state that the relay contacts (and generally speaking, all parts subject to dangerous voltage) shall be kept away from the very low safety voltage connections (probe, Televis serial, power supply) using insulation systems and distances providing at least a double or reinforced insulation.

However EMC requirements for correct operation suggest/impose better accuracy in such separation by using separated insulating pipes and special cable fixing systems.

EWPX ECHO (version /E only) operates at very low safety voltage and shall be installed respecting the same insulation/separation conditions from the parts bearing voltage and the wires of the relay contacts.

### ERROR MESSAGES

EWPX 185(/E) displays label "dte" (defrost time Error) in case of loss of the real time data (see section "programming real time").

The instrument also displays error message "E1" in case of shorted, interrupted or disconnected probe or in case of "under range", i.e. in case the lower display limit is exceeded ( $-55\text{ }^{\circ}\text{C}$ ) or "over range", when the upper display limit is exceeded ( $125\text{ }^{\circ}\text{C}$ ).

Error message "E2" refers to the evaporator probe (defrost end) for the above reasons. In case of error the alarm LED is immediately enabled.

Before proceeding to the probe replacement check its connections.

### TECHNICAL DATA

**Housing:** PC-ABS plastic resin, extinguishing grade V0.

**Size:** front panel 76x34 mm, depth 58 mm.

**Mount:** on panel hole size 71x29 mm.

**Protection:** front IP65.

**Connections:** on screw terminal blocks for wires max  $2.5\text{ mm}^2$  (one wire per terminal according to VDE regulations) for other connections.

**Remote connection:** double serial port for the connection to the EWPX ECHO 1 e 2 repeater (version /E only).

**Serial connection:** TTL port for the EWRS 485 interface for the connection to the Televis system.

**Display:** 3 digits 12.5 mm high.

**Commands:** all located on the front panel.

**Data storage:** on non-volatile memory

(EEPROM).

**Real time clock autonomy:** 5 hours approx.

**Operating temperature:**  $-5\dots 65\text{ }^{\circ}\text{C}$ .

**Storage temperature:**  $-30\dots 75\text{ }^{\circ}\text{C}$ .

**Outputs:** 2 outputs on N.O. relay for compressor and defrost system; 2 programmable outputs on exchange relay OUT 1 and OUT 2.

**Inputs:** three NTC probes for compressor, defrost and auxiliary; one programmable digital input.

**Measurement range:** from  $-50$  to  $100\text{ }^{\circ}\text{C}$  (from  $-58$  to  $212\text{ }^{\circ}\text{F}$ )

**Resolution:**  $1\text{ }^{\circ}\text{C}$ .

**Accuracy:** better than 0.5% end of scale.

**Consumption:** 3 VA (5 VA in the "/E" version when the ECHO module is connected)

**Power supply:** 12 Vac/dc  $\pm 15\%$ .

### Eliwell S.p.A.

via dell'Artigianato, 65  
Zona Industriale  
32010 Pieve d'Alpago (BL)  
Italy

Telephone +39 (0)437 986111

Facsimile +39 (0)437 989066

### A Siebe Group Company