

EWTS 70

rel. 1/98 ing

defrost timer 32x74

WHAT IT IS

The EWTS 70 has been designed specifically to be used as defrost timer in refrigeration systems.

HOW IT IS MADE

- **Housing material:** self-extinguish ABS plastic
- **Dimensions:** 32x74 mm (HxW); depth 67 mm
- **Mounting:** flush panel mount; bracket supplied
- **Protection:** front panel IP65: on request, a snap-on cover can be supplied to provide additional protection of the rear terminal block.
- **Connections:** screw terminal blocks for wires max 2,5 mm² (only one wire in per terminal in compliance with VDE regulations)
- **Commands:** on front panel and sideways (1 trimmer and 4 dip-switch)
- **Outputs:** 1 exchange relay 8(3)A 250V AC for defrost system
- **Digital input:** possibility of stopping the defrost through an external klixon thermostat
- **Defrost interval:** from 4 to 28 hours, with 4-hour increments
- **Defrost duration:** from 5 to 60 minutes in two different scales (5'-30' and 30'-60')
- **Consumption:** 1 VA max
- **Power supply:** 12 Vac/dc, 50/60 Hz

GENERAL DESCRIPTION

EWTS 70 is a microprocessor-based timer for defrost management, designed to be used in refrigeration installations.

It has one relay output to control the defrost system. In this instrument the defrost output besides being commanded by a time-out time can also be commanded by an external klixon thermostat (not supplied). It is also possible to carry out manual defrosts by using the special key on the front panel.

A series of parameters (not visible and programmable by serial means only at the factory) allow configuring the instrument according to the specific application.

EWTS 70, available in 32x74 mm format for flush mounting, has the possibility of managing the interval between defrosts (settable from 4 to 28 hours with 4-hour increments) and the duration of defrosts (settable from 5 to 60 minutes in two different setting scales; see under "Commands and settings").

Time and temperature can be easily set, by using the mini trimmers with settings indications and the micro-switches which can be selected as shown on the table printed on the instrument itself. Two leds on the front panel indicate respectively the presence of voltage and the status of the defrost relay.

This defroster is available in the same format as ELIWELL's temperature regulators for flush mounting (EWPC series). This allows making up a modular control panel suitable for a modern refrigerator, while offering an aesthetically pleasant and functional solution which can be personalized.

PANEL LAY-OUT AND SYSTEM SET-UP

When the instrument is switched on the power-on led lights up and the lamp-test is carried out only by the defrost led for about 5 seconds.

The instrument has no display. There is a pushbutton to manually activate the defrost cycle: pressing it for at least 5 seconds and releasing it, under certain circumstances, starts a defrost cycle.

Power-on led: (green) line led, it indicates if the instrument is powered.

Defrost led: (yellow) led associated with defrost. It is on when defrost is in progress, and it blinks on and off in case of manual defrost.

"DEFROST INTERVAL" dip-switches: dip-switches (2, 3, 4) for selecting the interval between defrosts.

The defrost interval is obtained by adding the hour value assigned to the dip-switches 2, 3 and 4. For example, by setting only the dip-switch number 2 to ON (value: 4 hours), you obtain a 4-hour defrost interval; by setting dip-switches number 2 and 3 to ON (number 4 to OFF), you obtain a 12-hour defrost interval.

"DEFROST DURATION" dip-switch: dip-switch (1) to select the time scale concerning the defrost duration time selection; such time can be set by means of the slotted-head trimmer "DEFROST DURATION".

"DEFROST DURATION" trimmer: slotted-head trimmer to choose defrost duration, in minutes, within the range established by the position of dip-switch number 1.

OPERATION

When the instrument is powered, the "POWER ON" led lights up to indicate that the instrument is energized.

After the defrost interval time, the corresponding exchange relay will be activated (however, only if the klixon input is not open; short-circuit this input when not used). The "DEFROST" led will indicate the change of cycle.

Defrost will end once the time-out time elapses or when the klixon reaches the fixed defrost end temperature.

It is also possible to carry out manual defrosts by simply pressing the appropriate key on the front panel of the instrument.

The instrument is not influenced by the mains frequency. In case of feeding with direct current, the reference frequency is generated internally and therefore there could be slight variations in the time interval generation (maximum error: 1,5%).

After a power failure, the timer will restart its cycle as described above as soon as power is reestablished.

MECHANICAL MOUNTING

EWTS 70 is designed for flush mounting. Make a hole measuring 29x71 mm and insert the instrument, fixing it with the special bracket supplied. The operating temperature allowed for a correct operation ranges from -5 to 65 °C. Avoid mounting the instrument in very humid and/or dirty places; in fact, they are suitable for being used in environments having a normal or ordinary pollution level. Make sure that the area close to the cooling slits of EWTS 70 is well ventilated.

CONNECTIONS

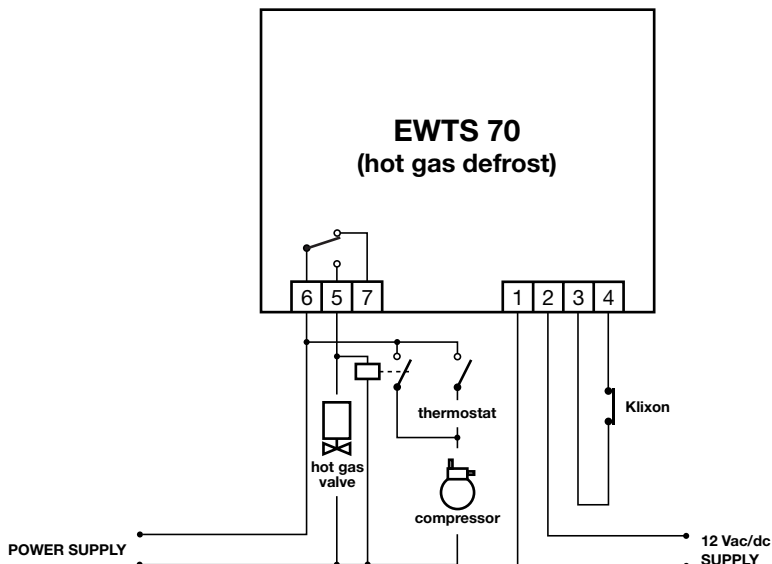
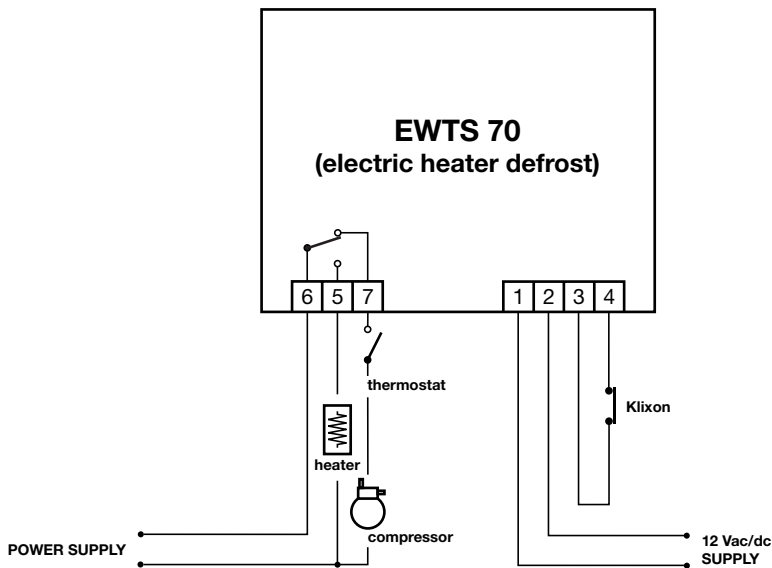

ELECTRIC WIRING

EWTS 70 is equipped with screw terminal blocks for electric wires with a maximum section of 2,5 mm² (only one wire on each terminal in compliance with VDE regulations).

The instrument has a SPDT output in exchange for the defrost system free from voltage.

Do not exceed the maximum capacity of the contacts: 8(3)A 250V AC. In case of heavier loads, use a contactor having a suitable power.

Make sure that the supply voltage conforms with the rating shown on the instrument.

The klixon input cables must be kept away from the relay cables and from the power cable, both for EMC and for safety rea-

sons. In particular, the coordinated European safety regulations impose that the wires of the relay contacts (and in general, all parts having a dangerous voltage) be kept apart from those having a very low safety voltage (probes) by using insulating systems and distances ensuring at least a double or reinforced insulation. However, EMC requirements for a correct operation advise/impose being more careful with such separation by using insulating pipes and suitable cable fixing methods.

TECHNICAL DATA

Housing: plastic made of PC+ABS resin, with auto-extinguishing degree V0.

Size: front panel 74x32 mm, depth 67 mm.

Mounting: flush with bracket (supplied)

into a hole measuring 71x29 mm.

Protection: front panel IP65: on request, a snap-on cover can be supplied to provide additional protection of the rear terminal block.

Connections: screw terminal blocks for wires max. 2,5 mm² (only one wire in per terminal in compliance with VDE regulations).

Commands: on front panel and sideways (1 trimmer and 4 dip-switches).

Data storage: on non-volatile (EEPROM) memory.

Operating temperature: -5...65 °C.

Storage temperature: -30...75 °C.

Outputs: 1 exchange relay 8(3)A 250V AC for defrost system.

Digital input: possibility of stopping the defrost through an external klixon thermostat.

Defrost interval: from 4 to 28 hours, with 4-hour increments.

Defrost duration: from 5 to 60 minutes in two different scales (5'-30' and 30'-60').

Consumption: 1 VA max.

Power supply: 12 Vac/dc, 50/60 Hz.

Eliwell S.p.A.

via dell'Artigianato, 65
Zona Industriale
32010 Pieve d'Alpago (BL)
Italy

Telephone +39 (0)437 986111

Facsimile +39 (0)437 989066

A Siebe Group Company