

# EWTS 72

rel. 1/98 ing

## defrost timer 32x74

### WHAT IT IS

The EWTS 72 has been designed specifically to be used as defrost timer in refrigeration systems.

### HOW IT IS MADE

- **Housing:** plastic made of PC+ABS resin, with auto-extinguishing degree V0
- **Size:** front panel 74x32 mm, depth 67 mm
- **Mounting:** flush with bracket (supplied) into a hole measuring 71x29 mm
- **Protection:** front panel IP65; on request, a snap-on cover can be supplied to provide additional protection of the rear terminal block
- **Connections:** screw terminal blocks for wires max 2,5 mm<sup>2</sup> (only one wire in per terminal in compliance with VDE regulations)
- **Commands:** 2 trimmers on the side for defrost end temperature and fan delay, and 1 dip-switch to select the defrost interval
- **Display:** leds on front panel.
- **Defrost interval:** from 2 to 30 hours with 2-hour increments
- **Defrost management:** NTC probe
- **Defrost end temperature:** adjustable from 3...15 °C
- **Forced defrost interruption:** after 1/2 an hour or 1 hour (depending on the model)
- **Defrost output:** exchange relay 8(3)A 250V AC
- **Fan startup delay:** adjustable from 1 to 8 minutes
- **Fans output:** N.O. relay 8(3)A 250V AC
- **Consumption:** 1 VA max
- **Power supply:** 12 Vac/dc, 50/60 Hz

### GENERAL DESCRIPTION

EWTS 72 is a microprocessor-based timer for defrost management, designed to be used in refrigeration installations.

A series of parameters which can only be accessed during the general test, make this instrument adaptable to various requirements.

EWTS 72 is available in flush mounting 74x32 mm format. It gives the possibility of managing the intervals between defrosts (from 2 to 30 hours, with 2-hour increments) by setting its dip-switches; the defrost end is determined by the reaching of the defrost end temperature (settable from 3 to 15 °C by using a trimmer) by a NTC temperature probe (supplied according to the order code).

Besides, this instrument allows commanding the stopping of fans during defrost and their restarting after defrost, once a delay which can be set by means of a trimmer has elapsed.

Time and temperature can be easily set, by using the mini trimmers with settings indications and the dip-switches which can be selected as shown on the table printed on the instrument itself. Several leds on the front panel allow you to see which cycle is in progress (normal, defrost, fans delay).

This defroster is available in the same format as ELIWELL's temperature regulators for flush mounting (EWPC series). This allows making up a modular control panel suitable for a modern refrigerator, while offering an aesthetically pleasant and functional solution which can be personalized.

### PANEL LAY-OUT AND SYSTEM SET-UP

**Led "ON":** (green) line led. When it is on it indicates that the instrument is energized.

**Led "DEFROST":** (yellow) defrost led. When it is on, it indicates that a defrost is in progress.

**Led "FANS":** (green) fans led. When it is on, it indicates that a delay of the activation of the fans is in progress.

**Dip-switch "DEFROST INTERVAL":** dip-switches to select the interval between defrosts.

The defrost interval is obtained by adding the hour value assigned to the dip-switches 1, 2, 3 and 4. For example, by setting only the dip-switch number 1 to ON (value: 2 hours), you obtain a 2-hour defrost interval; by setting dip-switches number 1 and 2 to ON (number 3 and 4 to OFF), you obtain a 6-hour defrost interval.

**Trimmer "DEFROSTING END":** slotted-

head trimmer to select the defrost end temperature.

**Trimmer "FAN DELAY TIME":** slotted-head trimmer to select the delay time, in minutes, to the fan activation after a defrost.

### OPERATION

When the instrument is powered, the "ON" led lights up to indicate that the instrument is energized.

Each time the instrument starts-up, it starts a defrost cycle (if the evaporator probe has reached a temperature lower than the defrost end one), the corresponding exchange relay is excited, and the "DEFROST" led lights up to indicate the change of cycle; the "FANS" Led extinguishes to indicate the stopping of the fans during defrost.

Defrost will end when the probe reaches the defrost end temperature or, if this does not happen within the time established as time-out (1/2 an hour or 1 hour, on request), by a forced interruption.

If after the defrost interval the temperature of the evaporator probe is higher than the preset limit, the following defrost will take place after the set interval time.

In the event of a possible failure of the probe, the defrost cycle will be exited by forced interruption after the time-out time has elapsed (intrinsic safety).

After defrost, the fans will remain off during the set delay time, and this situation will be indicated by the blinking of the "FANS" led. After such time, the fans will restart and the corresponding Led will remain on. It is also possible to carry out manual defrosts by simply installing in series with the 12 V power supply a normally closed pushbutton: by pressing it and releasing it the defrost will start.

The instrument is not influenced by the mains frequency. In case of feeding with direct current, the reference frequency is generated internally and therefore there could be slight variations in the time interval generation (maximum error: 1,5%).

### MECHANICAL MOUNTING

EWTS 72 is designed for flush mounting. Make a hole measuring 29x71 mm and insert the instrument, fixing it with the special bracket supplied.

The operating temperature allowed for a correct operation ranges from -5 to 65 °C. Avoid mounting the instrument in very humid and/or dirty places; in fact, they are suitable for being used in environments

## CONNECTIONS

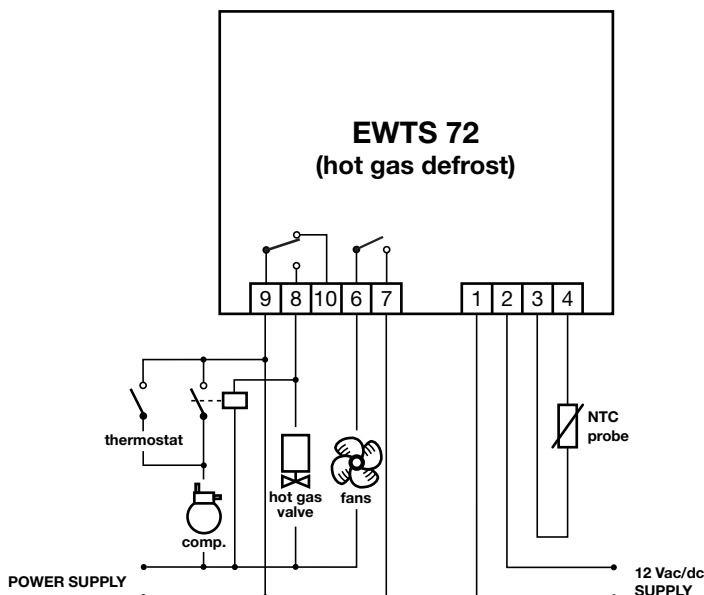
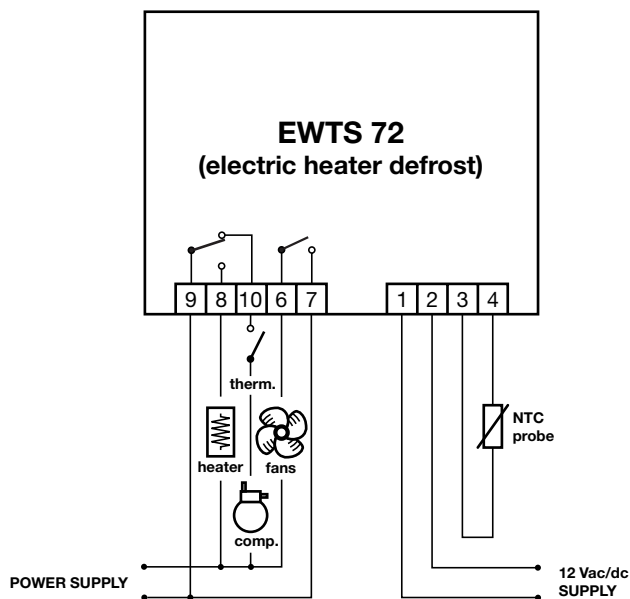

having a normal or ordinary pollution level. Make sure that the area close to the cooling slits of the instrument is well ventilated.

### ELECTRIC WIRING

EWTS 72 is equipped with screw terminal blocks for electric wires with a maximum section of 2,5 mm<sup>2</sup> (only one wire on each terminal in compliance with VDE regulations). The output is free from voltage.

The instrument has an output (contact in exchange) for defrost management and a N.O. output for the fans.

Do not exceed the maximum capacity of the contacts: 8(3)A 250V AC. In case of heavier loads, use a contactor having a suitable power.

Make sure that the supply voltage con-

forms with the rating shown on the instrument: 12 Vac/dc  $\pm 15\%$  (very low safety voltage).

The NTC-type probe is not polarity sensitive and it can be lengthened by using normal bipolar cable (remember that long probes worsen the performance of the instrument, from the EMC electromagnetic compatibility point of view).

The probe cable and the power supply cable must be kept away from the relay cables, both for EMC and for safety reasons. In particular, the coordinated European safety regulations impose that the wires of the relay contacts (and in general, all parts having a dangerous voltage) be kept apart from those having a very low safety voltage (probe, power supply) by using insulating

systems and distances ensuring at least a double or reinforced insulation. However, EMC requirements for a correct operation advise/impose being more careful with such separation by using insulating pipes and suitable cable fixing methods.

### TECHNICAL DATA

**Housing:** plastic made of PC+ABS resin, with auto-extinguishing degree V0.

**Size:** front panel 74x32 mm, depth 67 mm.

**Mounting:** flush with bracket (supplied) into a hole measuring 71x29 mm.

**Protection:** front panel IP65; on request, a snap-on cover can be supplied to provide additional protection of the rear terminal block.

**Connections:** screw terminal blocks for wires max 2,5 mm<sup>2</sup> (only one wire in per terminal in compliance with VDE regulations).

**Commands:** 2 trimmers on the side for defrost end temperature and fan delay, and 1 dip-switch to select the defrost interval.

**Display:** leds on front panel.

**Data storage:** on non-volatile (EEPROM) memory.

**Operating temperature:** -5...65 °C.

**Storage temperature:** -30...75 °C.

**Defrost interval:** from 2 to 30 hours with 2-hour increments.

**Defrost management:** NTC probe.

**Defrost end temperature:** adjustable from 3...15 °C.

**Forced defrost interruption:** after 1/2 an hour or 1 hour (depending on the model).

**Defrost output:** exchange relay 8(3)A 250V AC.

**Fan startup delay:** adjustable from 1 to 8 minutes.

**Fans output:** N.O. relay 8(3)A 250V AC.

**Accuracy:** depending on the supply frequency;  $\pm 15\%$  in case of direct current supply.

**Consumption:** 1 VA max.

**Power supply:** 12 Vac/dc, 50/60 Hz.

### Eliwell S.p.A.

via dell'Artigianato, 65  
Zona Industriale  
32010 Pieve d'Alpago (BL)  
Italy

Telephone +39 (0)437 986111

Facsimile +39 (0)437 989066

### A Siebe Group Company