

### USER INTERFACE

The user has a display and four keys for controlling status and programming of the instrument.

#### KEYS AND MENUS

UP key		Scrolls through the menu items Increases the values Activates manual def. function
DOWN key		Scrolls through the menu items Decreases the values Programmable by parameter
fnc key		ESC function (exit) Programmable by parameter
set key		Accesses the setpoint Accesses the menus Confirms the commands Displaying the alarms (if present)

At start-up the instrument performs a Lamp Test; for few seconds the display and the leds blink, in order to verify their integrity and correct operation. The instrument has two main menus: the “Machine Status” and “Programming” menu.

#### ACCESSING AND USING MENUS

Resources are arranged in a menu, which can be accessed by pressing and quickly releasing the “set” key (“Machine Status” menu) or by holding down the “set” key for more than 5 seconds (“Programming” menu).

To access the contents of each folder, indicated by the relevant label, just press the “set” key once.

You can now scroll through the contents of each folder, modify it or use its functions.

If you do not use the keyboard for over 15 seconds (time-out) or if you press the “fnc” key once, the last value shown on the display is confirmed and you return to the previous screen mask.

#### LED

Position	Related Function	Status
	Compressor or relay 1	ON when the compressor is started up; blinking in case of delay, protection or blocked enabling
	Defrost	ON when defrosting; blinking in case of manual enabling
	Alarm	ON when the alarm is enabled; blinking when the alarm is silenced

#### MACHINE STATUS MENU

To access the “Machine Status” menu Press and quickly release the “set” key. If alarms are not present, the label “SEt” appears. By using the “UP” and “DOWN” keys you can scroll through the other folders in the menu:

- AL: alarm folder (if present);
- Pb1: probe 1 value folder;
- Pb2: probe 2 value folder
- SEt: Setpoint setting folder.

#### Set Setting

Access the “Machine Status” menu by pressing and quickly releasing the “set” key. The label of the “SEt” folder appears. To display the Setpoint value press the “set” key again.

The value appears on the display.

To change the Setpoint value, use the “UP” and “DOWN” keys within 15 seconds.

If the parameter is LOC = y the Setpoint cannot be changed.

#### Alarm on

If alarm condition exists, when accessing The “Machine Status” menu the “AL” folder label appears (see the “Diagnostics” section).

#### Displaying Probes

By pressing the “set” key when the appropriate label appears, the value of the probe associated to it is displayed.

#### PROGRAMMING MENU

To enter the “Programming” menu, press the “set” key for more than 5 seconds. If specified, the access PASSWORD will be requested, (parameter “PA1”), and the label of the first folder will follow.

To scroll through the other folders, use the “UP” and “DOWN” keys; the folders contain the level 1 and 2 parameters. The level 2 parameters may be protected by a second password (parameter “PA2”).

To enter the folder, press “set”. The label of the first visible parameter appears. To scroll through the other parameters, use the “UP” and “DOWN” keys; to change the parameter, press and release “set”, then set the desired value using the “UP” and

“DOWN” keys, and confirm with the “set” key to move to the next parameter.

#### PASSWORD

The passwords “PA1” and “PA2” allow access respectively to level 1 and level 2 parameters. In the standard configuration passwords are not present.

To enable them and assign them the desired value, access the “Programming” menu, within the folder with the “diS” label. If passwords are enabled, you will see:

- PA1 at the entrance of the “Programming” menu;
- PA2 within the folder with the “Cnf” label containing level 1 parameters.

#### MANUAL ACTIVATION OF THE DEFROSTING CYCLE

To manually activate the defrosting cycle, press the “UP” key for 5 seconds.

If defrosting conditions are not present, (for example the evaporator probe temperature is higher than defrost stop temperature), the display will blink three (3) times, in order to indicate that the operation will not be performed.

#### COPY CARD

The Copy Card is an accessory connected to the TTL serial port which allows programming quickly the instrument parameters. The operation is performed as follows:

#### Format

This command allows copy card formatting, an operation recommended in case of first use.

Warning: if the copy card has been programmed, using the “Fr” the data entered are erased. This operation cannot be cancelled.

#### Upload

This operation loads the programming parameters from the instrument.

#### Download

This operation downloads to the instrument the programming parameters. The operations are performed accessing the folder identified by the “FPr” label and selecting, according to the case, “UL”, “dL” or “Fr” commands; the operation is confirmed by pressing the “set” key. If the operation is successful an “y” is displayed, on the contrary, if it fails a “n” will be displayed.

## TELEVIS SYSTEM

The link with the Televis system can go through the serial port TTL (the EWRS 485 interface module must be used).

In order to configure the instrument for this purpose you must access the folder identified by the "Add" label and use the parameters "dEA" and "FAA".

## KEYBOARD LOCKING

The instrument includes a facility for disabling the keyboard, by programming the "Loc" parameter (see folder with "diS" label). If the keyboard is locked, you can still access the programming menu by pressing the "set" key.

The Setpoint can also be viewed.

## DIAGNOSTICS

The alarm condition is always signalled by the buzzer (if present) and by the led of the alarm icon. (🔔)

The alarm signal produced by a faulty thermostat probe (probe 1) is shown as E1 on the instrument display.

The alarm signal produced by a faulty evaporator probe (probe 2) is shown as E2 on the instrument display. Other signalling alarm are not shown on the instrument display, but from the "Machine Status" menu within the "AL" folder. The signals for maximum and minimum alarms do not appear on the instrument display but are viewable on the "Machine Status" menu in the "AL" folder, with the label "AH1" or "AL1".

The regulation of the maximum and minimum temperature alarm refers to the room probe. The temperature limits are defined by the parameters "HAL" (maximum alarm) and "LAL" (minimum alarm).

DISPLAY	ALARM
AH1	High temperature alarm (referred to the thermostat probe or probe 1)
AL1	Low temperature alarm (referred to the thermostat probe or probe 1)
Ad2	End of defrost due to time-out
EA	Esternal alarm
oPd	Open door alarm

To silence alarms press any key.  
Alarms are related to Setpoint and are considered as the distance from the Setpoint itself.

## INSTALLATION

The instrument is designed for panel mounting. Make a hole of 29x71 mm, insert the instrument and fix it using the brackets provided. Do not mount the instrument in humid and/or dirty places; it is suitable for use in ordinary polluted places. Ventilate the place in proximity to the instrument colling slits.

## ELECTRICAL WIRING

Attention! Never work on electrical connections when the machine is switched on. The instrument is equipped with screw terminal boards for connection of electrical cables with a diameter of 2.5 mm<sup>2</sup> (one conductor only per terminal for power connections).

For the capacity of the terminals, see the label on the instrument.

The relay contacts are voltage free. Do not exceed the maximum current allowed; in case of higher loads, use an appropriate contactor. Make sure the power supply voltage complies with the one required by the instrument.

In 12V versions the power supply must be provided by a security transformer with the protection of a delayed 250 mA fuse. Probes have no connection polarity and can be extended using a regular bipolar cable (note that the extension of the probes affects the EMC electromagnetic compatibility of the instrument: pay extreme attention to wiring).

Probe cables, power supply cables and the TTL serial cables should be distant from power cables.

## CONDITIONS OF USE

### PERMITTED USE

For safety reasons the instrument must be installed and used according to the instruction provided and in particular, under normal conditions, parts bearing dangerous voltage levels must not be accessible.

The device must be adequately protected from water and dust as per the application and must also only be accessible via the use of tools (with the exception of the frontlet).

The device is ideally suited for use on household appliances and/or similar refrigeration equipment and has been tested with regard to the aspects concerning European reference standards on safety. It is classified as follows:

- according to its manufacture: as an automatic electronic control device to be incorporated by independent mounting;
- according to its automatic operating features: as a 1 B-type operated control type;
- as a Class A device in relation to the category and structure of the software

## UNPERMITTED USE

Any other use other than that permitted is de facto prohibited. It should be noted that the relay contacts provided are of a practical type and therefore subject to fault. Any protection devices required by product standards or dictated by common sense due to obvious safety reasons should be applied externally.

## LIABILITY AND RESIDUAL RISKS

Invensys Controls Italy S.r.L. shall not be liable for any damages deriving from:

- installation/use other than that prescribed and, in particular, that which does not comply with safety standards anticipated by regulations and/or those given herein;
- use on boards which do not guarantee adequate protection against electric shock, water or dust under the conditions of assembly applied;
- use on boards which allow access to dangerous parts without the use of tools;
- tampering with and/or alteration of the products;

## DISCLAIMER

This manual and its contents remain the sole property of Invensys Controls Italy s.r.l., and shall not be reproduced or distributed without authorization. Although great care has been exercised in the preparation of this document, Invensys Controls Italy s.r.l., its employees or its vendors, cannot accept any liability whatsoever connected with its use. Invensys Controls Italy s.r.l. reserves the right to make any changes or improvements without prior notice.

## TECHNICAL DATA

Frontal panel protection: IP65.

Casing: plastic body in resin type  
PC+ABS UL94 V-0, inspection window in polycarbonate, buttons in thermoplastic resin.

Dimensions: frontal panel 74x32 mm, depth 60 mm.

Installation: on panel, with drilling template 71x29 mm (+0.2/-0.1 mm).

Use temperature: -5...55 °C.

Storage temperature.: -30...85 °C.

Use environment humidity: 10...90 % RH (not condensing).

Storage environment humidity: 10...90% RH (not condensing).

Viewing range: -50...110 (NTC); -50...140 (PTC) °C without decimal point (selectable through parameter on 3 digit & 1/2 + mark display).

Analog inputs: two PTC or NTC inputs (programmable by parameter).

Digital input : 1 configurable low voltage digital input

Serial: TTL for connection to Copy Card or Televis system.

Digital outputs: 2 relay contacts: first contact SPDT 8(3)A 250V~ or SPST 15(1 Hp) 250V~, second contact SPST 8(3)A 250V~.

Measuring range: from -50 to 140 °C.

Accuracy: 0.5% better than end scale + 1 digit.

Resolution: 1 or 0.1 °C.

Power: 3 VA.

Power supply: 12 V~/= or 230V~.

Warning: check the power supply specified on the instrument label; for relay and power supply capacities, contact the Sales Office).



**Invensys Controls Italy s.r.l**

via dell'Industria, 15 Zona Industriale Paludi

32010 Pieve d'Alpago (BL) ITALY

Telephone +39 0437 986111

Facsimile +39 0437 989066

Internet <http://www.climate-eu.invensys.com>

4/2002 eng  
cod. 9IS42065

Tab. 1 Parameter Table

PAR.	DESCRIPTION	RANGE	DEFAULT	VALUE*	LEVEL**	U.M.
<b>COMPRESSOR REGULATOR (folder with "CP" label)</b>						
diF	differential. Relay compressor tripping differential. The compressor stops on reaching the Setpoint value (as indicated by the adjustment probe), and restarts at temperature value equal to the Setpoint plus the value of the differential. Note: the value 0 cannot be assumed.	0.1...30.0	2.0		1	°C/°F
HSE	Higher SET. Maximum possible setpoint value.	LSE...302	99.0		1	°C/°F
LSE	Lower SET. Minimum possible setpoint value.	-55.0...HSE	-50.0		1	°C/°F
OSP	Offset Setpoint: temperature value to be added algebraically to the setpoint in the case of reduced set enabled (Economy function). It can be activated through digital input or by a key configured for such use.	-30.0...30.0	0		2	°C/°F
Cit	Compressor min on time. Minimum compressor activation time before any possible disabling. If set at 0 it is not active	0...250	0		2	min
CAt	Compressor mAx on time. Maximum compressor activation time before any possible disabling. If set at 0 it is not active	0...250	0		2	min
dOd	digital (input) Open door. Digital input user shut off. y = yes; n = no. Valid for parameter "H11" = ±4 (door switch).	n/y	n		2	flag
dAd	digital (input) Activation delay. Delay time of digital input activation.	0...255	0		2	Min.
<b>COMPRESSOR PROTECTIVE DEVICE (folder with "CP" label)</b>						
Ont	On time (compressor). Compressor activation time in the event of faulty probe. If set to "1" with Offt at "0" the compressor is always on, while at Oft >0 it functions always in duty cycle mode.	0...250	0		1	min
OfT	OFF time (compressor). Compressor in disabled state time in the event of a faulty probe. If set to "1" with Ont at "0" the compressor is always off, while at Ont >0 it functions always in duty cycle mode.	0...250	1		1	min
dOn	delay (at) On compressor. Delay time in activating the compressor relay after switch-on of instrument	0...250	0		1	sec
dOF	delay (after power) OFF. Delay after switch off; the indicated time must elapse between switch-off of the compressor relay and the successive switch-on.	0...250	0		1	min
dbi	delay between power-on. Delay between switch-ons; the indicated time must elapse between two successive switch-ons of the compressor.	0...250	0		1	min
OdO	delay Output (from power) On. Delay time in activating the outputs after switch-on of the instrument or after a power failure.	0...250	0		1	min
<b>DEFROSTING REGULATOR (folder with "dEF" label)</b>						
dty	defrost type. Type of defrosting. 0 = electric defrost; 1 = reverse cycle defrost (hot gas); 2 = Free defrost (compressor hot).	0/1/2	0		1	flag
dit	defrost interval time. Interval between the start of two successive defrosting operations.	0...250	6		1	hours
dt1	defrost time 1. Measure unit for defrosting intervals ("dit" parameter). 0 = "dit" parameter in hours; 1 = "dit" parameter in minutes; 2 = "dit" parameter in seconds.	0/1/2	0		2	flag
dt2	defrost time 2. Measure unit for defrosting duration ("dEt" parameter). 0 = "dEt" parameter in hours; 1 = "dEt" parameter in minutes; 2 = "dEt" parameter in seconds.	0/1/2	1		2	flag
dCt	defrost Counting type. Selection of count mode for the defrosting interval. 0 = compressor operating hours (DIGIFROST® method); 1 = Real Time – appliance operating time; 2 = compressor stop.	0/1/2	1		1	flag
dOH	defrost Offset Hour. Start-of-defrosting delay time from start up of instrument.	0...59	0		1	min
dEt	defrost Endurance time. Defrosting time-out; determines duration of defrosting.	1...250	30		1	min
dSt	defrost Stop temperature. Defrost stop temperature (defined by the evaporator probe).	-50.0... 150	8.0		1	°C/°F
dPO	defrost (at) Power On. Determines if at the start-up the instrument must enter defrosting (if the temperature measured by the evaporator allows this operation). y = si; n = no.	n/y	n		1	flag
tcd	time compressor for defrost. Minimum time for compressor On or OFF before defrost.	-31...31	0		2	min
Cod	Compressor off (before defrost). Time for compressor OFF in proximity of the defrost cycle. If a defrost cycle is set within the programmed time for this parameter, the compressor is not started up.	0...60	0		2	min
<b>FAN REGULATOR (folder with "FAn" label)</b>						
dt	drainage time. Dripping time.	0...250	0		1	min
<b>ALARMS (folder with "AL" label)</b>						
Att	Alarm type. Parameter "HAL" and "LAL" modes, as temperature absolute values or as differential compared to the Setpoint. 0 = absolute value; 1 = relative value.	0/1	0		2	flag
AFd	Alarm Fan differential. Alarm differential.	1.0...50.0	2.0		1	°C/°F
HAL	Higher ALarm. Maximum temperature alarm. Temperature value (with regard to Setpoint) which if exceeded in an upward direction triggers the activation of the alarm signal.	LAL...150.0	50.0		1	°C/°F
LAL	Lower ALarm. Minimum temperature alarm. Temperature value (with regard to Setpoint), which if exceeded in a downward direction, triggers the activation of the alarm signal.	-50.0...HAL	-50.0		1	°C/°F
PAO	Power-on Alarm Override. Alarm exclusion time after instrument switch on, after a power failure.	0...10	0		1	hours
dAO	defrost Alarm Override. Alarm exclusion time after defrost.	0.999	0		1	min
OAO	Output (door) Alarm Override. Delay time for temperature alarm signalling after disabling of digital input (or gate closure).	0...10	0		2	hours
tdO	Time-out Door Open. Alarm signalling delay time for gate open.	0...250	0		2	minutes
tAO	temperature Alarm Override. Temperature alarm signal delay time.	0...250	0		1	min
dAt	defrost Alarm time. Alarm for defrost end due to time-out. n = enables alarm; y = does not enable alarm.	n/y	n		2	flag
EAL	External Alarm Lock. External alarm for regulators stop. Allows the blocking of compressor, defrosting and fan regulators if the digital input (configured as external alarm) is activated. n = not block; y = block.	n/y	n		2	flag

PAR.	DESCRIPTION	RANGE	DEFAULT	VALUE*	LEVEL**	U.M.
AOP	Alarm Output Polarity. Polarity of alarm output. 0 = alarm activated and output disabled; 1 = alarm activated and output disabled.	0/1	1		2	flag
<b>COMMUNICATION (folder with label "Add")</b>						
dEA	dEvice Address. Device address: indicates the appliance address to the management protocol	0..14	0		1	num
FAA	FAmily Address. Family address: indicates the appliance family to the management protocol	0..14	0		1	num
<b>DISPLAY (folder with "diS" label)</b>						
LOC	(keyboard) LOck. Keyboard locking. However, you can enter parameter programming modify them along with the status of this parameter in order to allow keyboard locking. y = yes; n = no	n/y	n		1	flag
PA1	PASsword 1. When enabled (value other than 0) it constitutes the access key for level 1 parameters.	0..250	0		1	number
PA2***	PASsword 2. When enabled (value other than 0) it constitutes the access key for level 2 parameters.	0..255	0		2	number
ndt	number display type. View with decimal point. y = yes; n = no	n/y	y		1	flag
CA1	CAlibration 1. Calibration 1. Positive or negative temperature value added to the value read by probe 1, based on "CA" parameter settings.	-12.0..12.0	0		1	°C/°F
CA2	CAlibration 2. Calibration 2. Positive or negative temperature value added to the value read by probe 1, based on "CA" parameter settings.	-12.0..12.0	0		1	°C/°F
CA	CAlibration Intervention. Intervention on view offset, thermostat offset or both. 0 = modifies the temperature displayed only; 1 = adds to the temperature used by regulators, not to the temperature displayed, which stays unchanged. 2 = adds to the temperature displayed that is also used by regulators.	0/1/2	2		2	num
LdL	Low display Label. Minimum value the instrument is able to display.	-55.0..302	-55.0		2	°C/°F
HdL	High display Label. Maximum value the instrument is able to display.	-55.0..302	140.0		2	°C/°F
ddl	defrost display Lock. Viewing mode during defrosting. 0 = shows the temperature read by the thermostat probe; 1 = locks the reading on the temperature value read by thermostat probe when defrosting starts, and until the next time the Setpoint value is reached; 2 = displays the label "deF" during defrosting, and until the next time the Setpoint value is reached.	0/1/2	1		1	flag
dro	display read-out. Select °C or °F for displaying the temperature read by the probe. 0 = °C, 1 = °F.	0/1	0		1	flag
ddd	Selection of the value type to be shown on the display. 0 = Setpoint; 1 = probe 1; 2 = probe 2.	0/1/2	0		2	num
<b>CONFIGURATION (folder with "CnF" label)</b>						
H00 (1)	Probe type selection, PTC or NTC. 0 = PTC; 1 = NTC.	0/1	0		1	flag
H02	Time to enable keys, if these are configured for a specific function.	0..15	5		2	sec
H11 (2)	Configurability digital inputs/polarity. 0 = disabled; ± 1 = defrosting; ± 2 = reduced set; ± 3 = not used; ± 4 = door switch; ± 5 = external alarm.	-5..5	0		2	flag
H21	Configurability digital output 1. 0 = disabled; 1 = compressor; 2 = defrosting; 3 = fans; 4 = alarm; 5 = optional.	0..5	1		2	flag
H22	Digital output 2 configurability. Same as H21.	0..5	2		2	flag
H31	Configurability UP key 0 = disabled; 1 = defrosting; 2 = not used; 3 = reduced set (economy).	0..4	1		2	num
H32	Configurability DOWN key 0 = disabled; 1 = defrosting; 2 = not used; 3 = reduced set (economy).	0..4	0		2	num
H33	Configurability FNC key 0 = disabled; 1 = defrosting; 2 = not used; 3 = reduced set (economy).	0..4	0		2	num
H41	Regulating probe present.	n/y	y		2	flag
H42	Evaporator probe present.	n/y	y		1	flag
reL	release firmware. Device version: read only parameter.	/	/		1	/
tAb	tAble of parameters. Reserved: read only parameter.	/	/		1	/
<b>COPY CARD (folder with "Fpr" label)</b>						
UL	Up load. Programming parameter transfer from instrument to Copy Card.	/	/		1	/
dL	Down load. Programming parameter transfer from Copy Card to instrument	/	/		1	/
Fr	Format. Erasing all data in the copy card.	/	/		2	/

**NOTA BENE: using "Fr" parameter (copy card formatting) the data within the copy card will be lost permanently. The operation cannot be cancelled.**

(1) For 230 V~ models the default value is 1 (NTC input, see the label on the instrument).

(2) Positive values: active input for on contact; negative values: active input for off contact.

\* VALUE column: to be filled manually, with customized settings (if different from the default value).

\*\* LEVEL column: indicates the level of visibility of parameters accessible by PASSWORD (see the related paragraph)

\*\*\* PA2 is visible (it will be required, if necessary) at level 1 and can be set (editable) at level 2

Wiring diagram

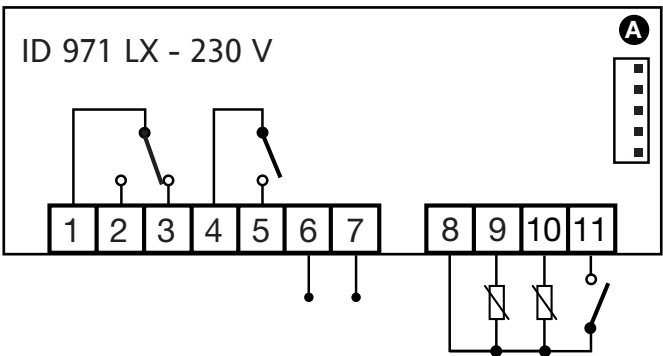
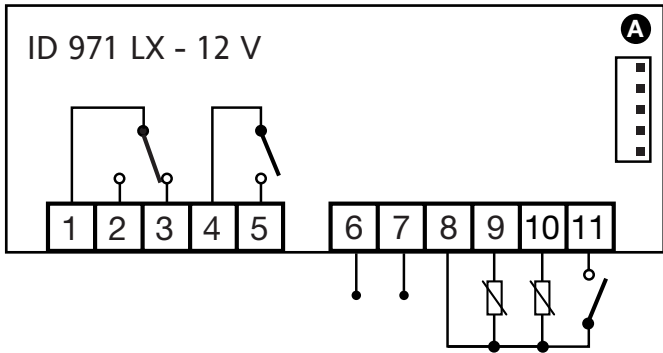

**TERMINALS**

1 - 2	N.O. defrost relay
1 - 3	N.C. defrost relay
4 - 5	Compressor relay output
6 - 7	Power supply
8 - 9	Probe 2 input (evaporator)
8 - 10	Probe 1 input (thermostat)
8 - 11	Digital input
A	TTL input for Copy Card and connection to Televis system

**NOTE:** Default user settings