

LTS12

We thank you for choosing an LAE electronic product. Before proceeding to the installation of this unit, please read this instructions sheet carefully; only in this way you will obtain maximum performances and safety.

1. INSTALLATION

1.1 LTS12 has got a size of 77x35x77 mm (WxHxD), it must be inserted into the panel through a 71x29 mm hole and secured via the suitable brackets exerting correct strength. The rubber gasket must be placed between the panel and the instrument front, so please make sure that there are no gaps allowing liquid infiltrations.

1.2 The unit works with an ambient temperature between -10°C.. +50°C and 15%.. 80% relative humidity. To reduce the effects of electro-magnetic interference, place the probe cable and the unit itself as away as possible from power lines.

1.3 Probe and power supply must be connected strictly following the diagram appearing on the enclosure. If present, the probe screen must be earthed, by connecting it to the metal frame. If needed, the unit must be powered by means of the suitable transformer mod. TRxxx.

Where delicate or valuable products have to be maintained under strict conditions, please use a separate controller for limit and alarm functions.

2. CONFIGURATION (SETUP)

Thanks to the configuration parameters, the LTS12 can suit scale, resolution and sensor type. Access to the configuration takes place through the following sequence: switch off the unit, keep buttons **↵**+**↵** pressed, then switch on unit again. Scroll through the parameter list with **↵** or **↶** until you get to the desired one, then get its value displayed with **↵** and change it with **↵**+**↵** or **↶**.

Exit from the SETUP takes place by letting the keypad untouched for 10 seconds.

SCL Readout scale	01=normal, 02=°F
ACC Resolution	01=1; 02=0.1; 03=autorange
TYP Type of sensor	0; 1
LOR Minimum range limit	-199 .. 999
HOR Maximum range limit	-199 .. 999
SIM Display indication slowdown	0 .. 100
LAD Zero calibration	--
HAD Span calibration	--

Parameter **SCL** provides the readout scale, i.e.: with SCL=01 there is no modification of the measured value, while with SCL=02, there is a scale conversion from °C to °F (to be used for temperature measurements only). In this latter case, 0.1 resolution is not available.

With SCL=01 resolution is based upon the value set to **ACC**; with ACC=01 or 02 resolution is set to respectively 1 or 0.1. With ACC=03 you will obtain the maximum resolution allowed by the display, i.e.: 0.1 for values between -19.9 and 99.9 and 1 outside of these limits.

Through **SIM** it's possible to simulate different sensor response times to changes of the value measured, therefore: by setting SIM to values greater than 0, the resulting effect will be a proportional reduction of the displayed data change.

If the model you own accepts two types of input, then select the one you want to use by means of parameter **TYP** following the table here below:

MODEL	TYP=0	TYP=1
LTS12 PT	Pt100 DIN43760	PTC KTY81-121
LTS12 TC	T/C "J" Fe-CuNi	T/C "K" NiCr-Ni
LTS12 AV	----	0... 1V

3. DISPLAYS

At the power up the unit shows "-" during 3 seconds approximately during which it performs a self-check, then the current value according to the configuration set appears. If SIM is different from 0 it's possible to display the instantaneous value by pressing $\text{[]} + \text{[]}$.

LTS12 permanently stores the minimum and maximum values measured during the normal operation. The stored values are displayed by respectively pressing button [] or [] and cleared by pressing button [] for 1 second.

If the readout exceeds the limits programmed with **LOR** and **HOR**, then "or" is displayed, while in case of probe failure the indication "PF" appears.

4. RE-CALIBRATION

Should it be necessary to re-calibrate the unit, then act in the following way: get an accurate calibrator to be connected to the LTS12 input; then get into the unit configuration (see paragraph 2), and select parameter **LAD** or **HAD**. First act on LAD then on HAD. LAD allows 0 calibration (32°F if SCL=02) by adding a constant offset all over the range; HAD allows span calibration with a proportional offset between the calibration point and 0. After having selected the desired value, press [] to display the measured value and adjust it with $\text{[]} + \text{[]}$ or [] .

WARRANTY

LAE electronic Srl warrant that their products are free of any defects in workmanship and materials for a period of 1 (one) year from date of production shown on the enclosure. LAE electronic Srl shall only repair or replace those products of which defects are due to LAE electronic Srl and recognised by their technicians. LAE electronic Srl are not liable for damages resulting from malfunctions of the products.

Defects due to exceptional operating conditions, misapplication and/or tampering will void the warranty.

All transport charges for returning the product to the manufacturer, after prior authorisation by LAE electronic Srl, and for the return to the purchaser are always for the account of the purchaser.

WIRING DIAGRAM

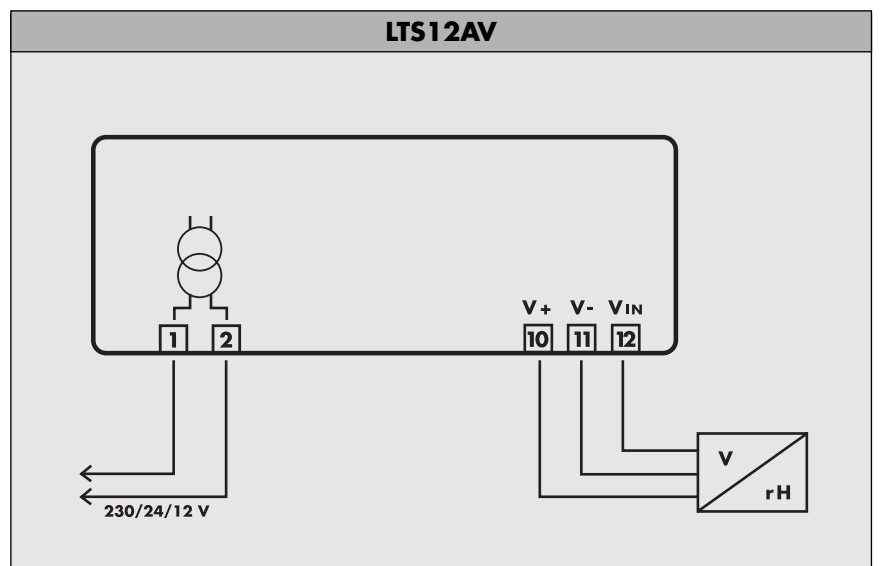
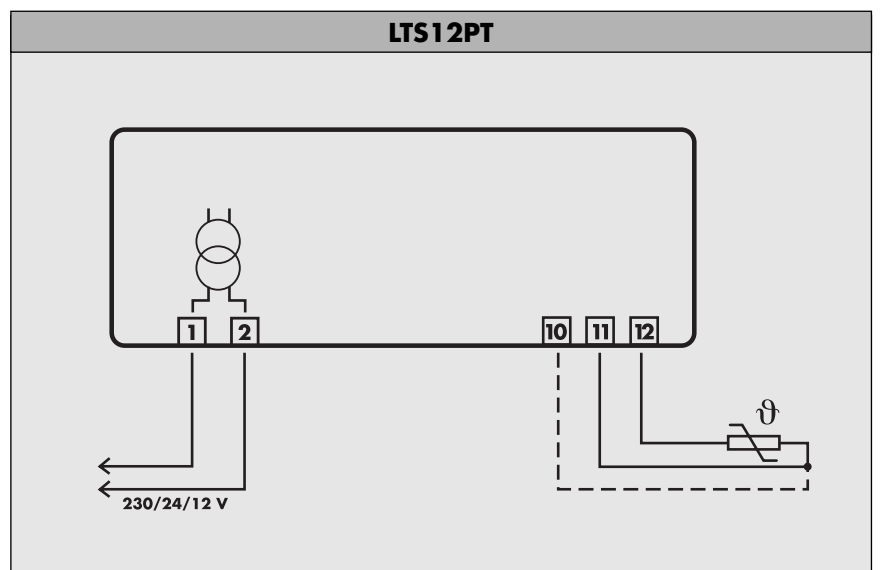
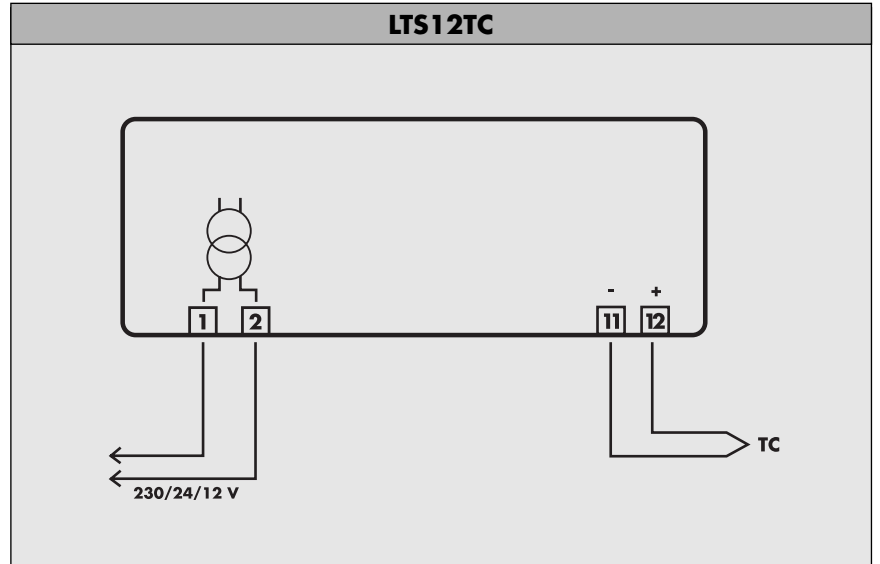

NOTE: the cable with three wire compensation must be used for all Pt100 probes and for PTC1000 probes longer than 5 metres. For PTC probes of shorter lengths it's possible to use a two wire cable and make a junction between terminals 10 and 11.

PARTNER VENEZIA • 041 5460713