

WIRING DIAGRAM

INSTRUCTIONS FOR INSTALLATION AND USE OF MTR6, MTR12, MTR122, MHC122.

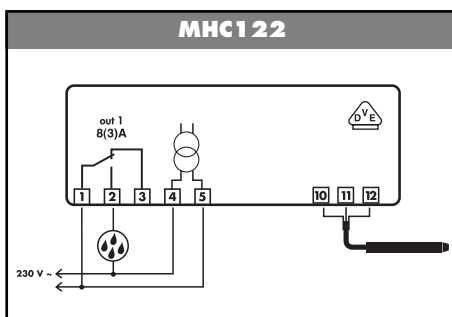
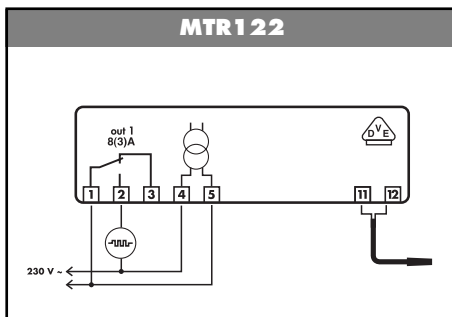
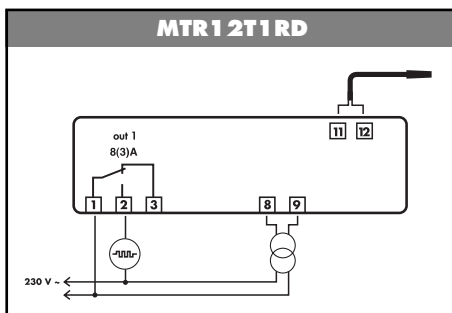
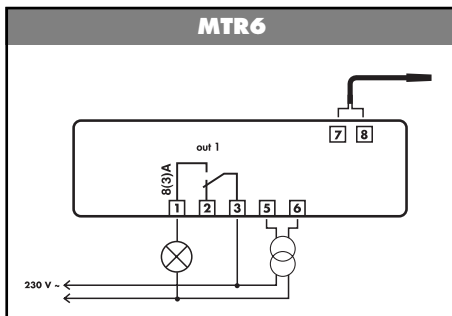

TECHNICAL DATA

	MTR6	MTR12	MTR122	MHC122
Dimensions	64x32x81 mm	77x35x77 mm	77x35x77 mm	77x35x77 mm
Operating temp.	-10°...+50°C	-10°...+50°C	-10°...+50°C	-10°...+50°C
Range	-50°...+150°C	-50°...+150°C	-50°...+150°C	0...100% r.H.
Resolution	1°C	1°C	1°C	1% r.H.
Input	PTC 1000	PTC 1000	PTC 1000	0...1V
Relay power rating	refer to data on unit	refer to data on unit	refer to data on unit	refer to data on unit
Connections	screw terminal blocks, Ø 2 mm ²	screw terminal blocks, Ø 2 mm ²	screw terminal blocks, Ø 2 mm ²	screw terminal blocks, Ø 2 mm ²
Supply voltage	12 Vac/dc	12 Vac/dc	refer to data on unit	refer to data on unit
Consumption	2VA	2VA	2VA	2VA
Front panel protection	IP54	IP54	IP54	IP54
Enclosure inflammability	fire-retardant	fire-retardant	fire-retardant	fire-retardant

We reserve the right to make modifications without prior notice.

lae®
ELECTRONIC

VIA PADOVA, 25
31046 ODERZO /TV /ITALY
TEL. 0039 0422 815320 - 815303
TELEFAX 0039 0422 0422 814073
www.lae-electronic.com
E-mail: info@lae-electronic.com

1 INTRODUCTION

MTR is a particularly flexible controller, which allows On/Off control of your refrigeration (dehumidification) or heating (humidification) plant.

To get best performance, before installing and using it, read this instruction sheet carefully.

1a **MTR** has one output which is controlled by a microprocessor according to the values programmed for the parameters in SETUP .

1b The display, during the basic functioning of **MTR**, shows the variable measured by the probe but, when programming, is used to indicate the values chosen for the control parameters and the respective symbols, useful to simplify understanding.

The parameters are shown and set by using the four keys on front.

2 INSTALLATION

2a The instrument is secured to the panel from the rear by means of the suitable brackets, exerting correct strength. If using the rubber gasket ("S" version), this must be interposed between the panel and the instrument bezel, checking the perfect adhesion carefully.

2b For proper functioning the instrument needs an ambient temperature between -10°...+50°C and 15%...80% relative Humidity. To improve protection of the probe against electro-magnetic interference, which might compromise its function, place its cable and the controller away from power lines.

2c Output, power supply and probe must be connected strictly following the diagram indicated on the enclosure. The probe screen must not be connected to any other leads. If the external transformer is needed, the instrument must be powered by the suitable transformer supplied by LAE (mod. TR...). As to the maximum load that can be controlled by the output and the supply voltage, refer to the maximum value on the label.

2d Should the instrument be recalibrated, in consequence of probe replacement or considerable cable lengthening, then proceed as follows: with an accurate thermometer measure the exact temperature, immersing the two probes in a liquid if necessary; by means of a screwdriver turn the trimmer accessible through the hole "0 ADJ.". With respect to the humidity probe please consult relevant instruction sheet.

CAUTION:

- *If the relay switches a large load frequently, we suggest you contact us to obtain information about the relay contact life.*
- *Where delicate or valuable products have to be maintained in special conditions, the same instrument should not be used for both control and limit functions. In such cases a separate instrument for each function is recommended.*

3 FUNCTIONING DESCRIPTION

In the following description reference is made to HEATING (HUMIDIFICATION) or

REFRIGERATION (DEHUMIDIFICATION) control to express a different way of controlling the output. In both cases the set point is the On to Off switch point but, in refrigeration (dehumidification) control, values lower than this will confirm the Off status, while in heating (humidification) control they will cause the output to switch On.

3a Keys \blacktriangle and \blacktriangledown . After having displayed the parameter to be changed with keys \square or \square , press key \blacktriangle briefly to increase the value by one unit or \blacktriangledown to decrease it. Keeping it pressed results in a progressively faster variation. The minimum and maximum limits are programmed in SETUP; to modify them proceed as per **4a** and subsequent.

3b Key \square . By pressing it during the basic functioning of **MTR**, "L1" is displayed for 2 sec. followed by the pre-programmed value. "L1", once reached by the input, causes RL1 output to switch from On to Off.

Key \square , if pressed when programming a parameter, allows its immediate storage with subsequent **MTR** switchover to control function. The same sequence takes place automatically if no key is pressed within 6 sec.

3c Key \square . It allows to display the hysteresis value. "HY1" is displayed for 2 sec., followed by the pre-programmed value, positive for refrigeration (dehumidification) control, negative for heating (humidification). The hysteresis represents the difference between the switch On and the switch Off value. The output On status is displayed by the lighting up of the Led located near the indication RL1.

*Example 1) L1 = +25°C; HY1 = -03°K
The output is set for heating control: it will be switched Off at the temperature of +25°C and will be switched On at +22°C.*

*Example 2) L1 = -10°C; HY1 = +02°K
In this case the instrument is programmed for refrigeration: RL1 will be switched Off at -10°C and switched On at -08°C.*

3d As a result of probe failure, its connection breakdown or overrange, "PFA" is displayed and RL1 output will permanently operate as programmed in SETUP.

4 SETUP

MTR configuration is made through programming of the control parameters. Access to it is possible through a sequence of operations preventing accidental activation.

4a Switch off the unit; press keys \blacktriangle and \blacktriangledown and, by keeping them pressed, switch on the unit again; "PAR" appears on display. Parameter selection and the display of the value is obtained by pressing key \square repeatedly; change with keys \blacktriangle and \blacktriangledown and store with \square .

To skip from one parameter to the next without displaying the value, press key \blacktriangledown . It's also possible to select a specific parameter and change its value by following the diagram attached.

4b Parameter description:

vSP: minimum setpoint limit (-50°...+150°C); (0...100%).

^SP: maximum setpoint limit (vSP...+150°C); (vSP...100%).

rt1: minimum Off time for RL1. It determines the minimum Off time between the switch Off and the switch On of RL1, regardless of the input values (0...10 minutes).

PFI: permanent status assigned to RL1 output in case of probe failure (On...Off).

ADJ: offset which, added to the value read by the input, allows to alter the read out (-20...+20).

hY1*: it determines RL1 Off to On switching hysteresis programmable range. With the sign + or - you select the control carried out by RL1: refrigeration (dehumidification) with positive sign, heating (humidification) with negative sign (-25...+25).

After programming, switch off the unit. When **MTR** is switched on again, it will work according to the new configuration.

***ATTENTION: when programming the hysteresis hY1, please consider the number of switchings that can be performed by the relay, and if necessary adjust the rest time rt1 to limit the switching frequency.**

WARRANTY

LAE electronic Srl warrant that their products are free of any defects in workmanship and materials for a period of 1 (one) year from date of production shown on the enclosure. LAE electronic Srl shall only repair or replace those products of which defects are due to LAE electronic Srl and recognised by their technicians. LAE electronic Srl are not liable for damages resulting from malfunctions of the products.

Defects due to exceptional operating conditions, misapplication and/or tampering will void the warranty. All transport charges for returning the product to the manufacturer, after prior authorisation by LAE electronic Srl, and for the return to the purchaser are always for the account of the purchaser.

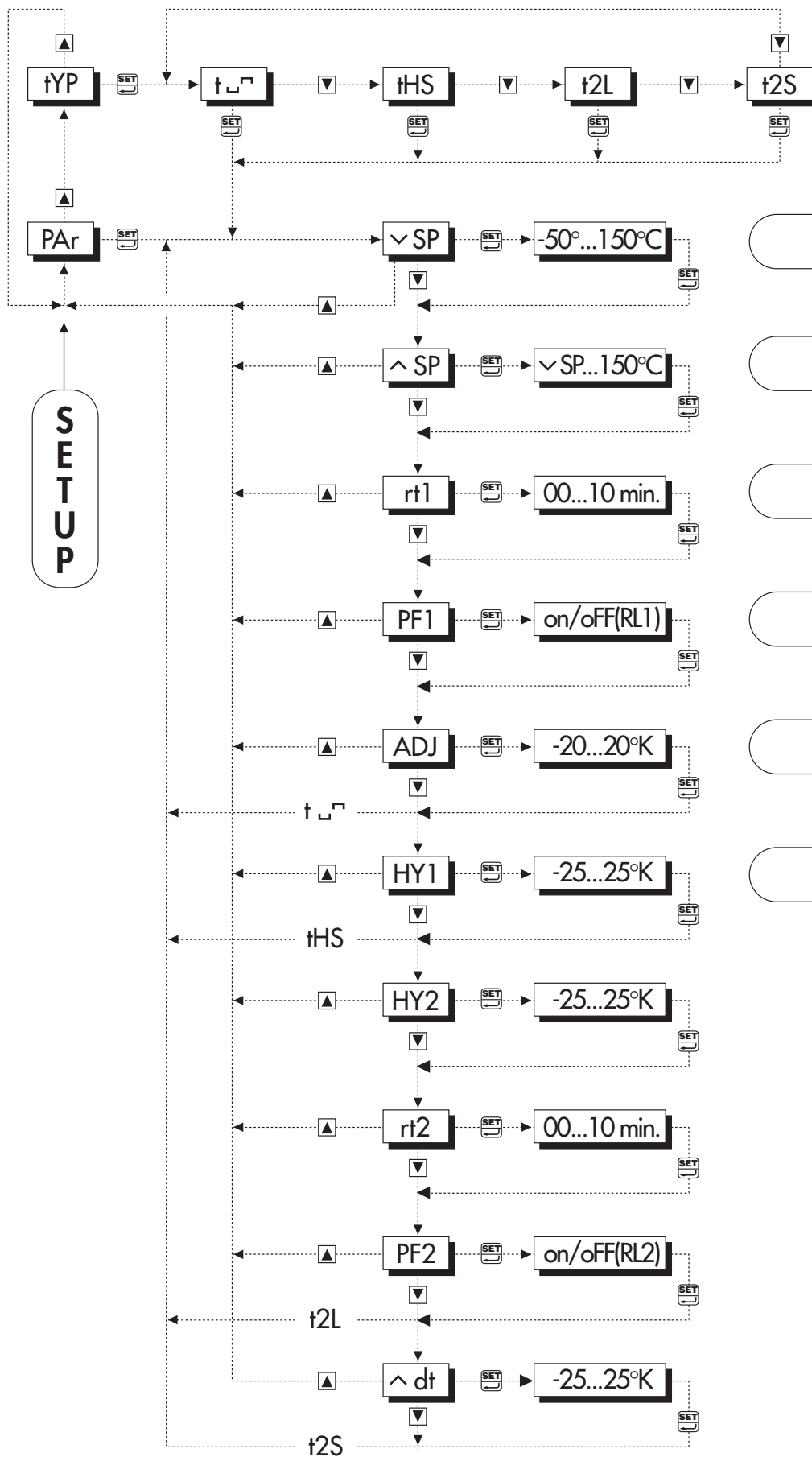



Regolatore ad 1 limite
1 limit controller
Régulateur à 1 P.d.C.
Zweipunktregler
Regulador de 1 límite

- 
 Set Point minimo
Minimum Set Point
 P.d.C. minimum
Minimaler Sollwert
 Mínimo Punto de Ajuste

- 
 Set Point massimo
Maximum Set Point
 P.d.C. maximum
Maximaler Sollwert
 Máximo Punto de Ajuste

- 
 Fermata minima RL1
RL1 Rest Time
 Arrêt minimum RL1
Min. RL1-Auszeit
 Parada Mínima RL1

- 
 Stato di RL1 con sonda difettosa
RL1 with Probe Failure
 RL1 avec sonde défectueuse
RL1 bei Fühlerfehler
 Estado de RL1 con fallo de la sonda

- 
 Correzione sonda
Probe Offset
 Correction Sonde
Fühler-Abgleichung
 Corrección Sonda

- 
 Isteresi di RL1
RL1 Hysteresis
 Hystérésis RL1
RL1-Schalhysterese
 Histéresis de RL1